

Pre-installation Manual



Plate Processors
85/125

Pre-installation

Plate Processors 85/125

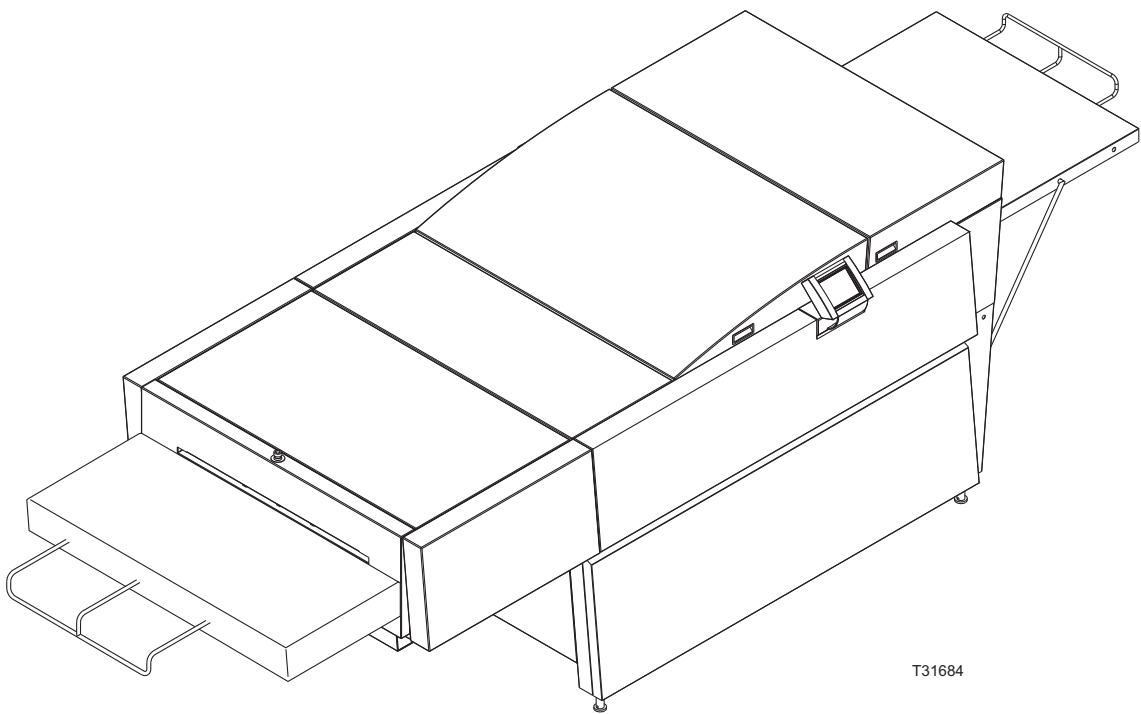

T31684

This manual is published by: **GLUNZ & JENSEN A/S**
Haslevvej 13,
DK-4100 Ringsted
Denmark
Phone: +45 57 68 81 81
E-mail: gjhq@glunz-jensen.com
Internet: www.glunz-jensen.com

Copyright © 2007 by GLUNZ & JENSEN A/S.

Part 0: Introduction

This guide covers: **Polymer CTP Plate Processors 85/125.**

Reservations

This manual was written and illustrated using the best possible information available at the time of publication.

Any differences between this manual and the equipment reflect improvements introduced after the publication of the manual.

Changes, technical inaccuracies and typographic errors will be corrected in subsequent editions.

As a part of our policy of continuous improvement, we reserve the right to alter design and specifications without further notice.

Pre-installation instructions

The instructions in this Pre-Installation Guide allow the customer and the Service Technician to prepare the installation of the plate processor.



Only qualified Service Technicians are allowed to unpack and install the equipment.

Notes, Cautions and Warnings

Throughout the manual warnings, cautions, and notes are written in bold like the example below:



Electrical installation must conform to local regulations and guidelines.

Symbol	Meaning	Explanation
	Note	The operator should observe and/or act according to the information in order to obtain the best possible function of the equipment.
	Caution	The operator must observe and/or act according to the information in order to avoid any mechanical or electrical damage to the equipment.
	Warning	The operator must observe and/or act according to the information in order to avoid any personal injury.

Table of Contents

Part 0: Introduction	0.1
Reservations	0.1
Pre-installation instructions	0.1
Notes, Cautions and Warnings	0.1
Part 1: Transportation	1.1
When the processor arrives	1.1
Storing the processor before installation	1.1
The crate	1.1
Dimensions and weight	1.1
Checking the crate for damage	1.2
Handling the crate	1.2
Transporting the processor	1.3
Lifting the crate	1.3
Available width for transport	1.3
Part 2: Installation requirements	2.1
Environmental requirements	2.1
Cleaning facilities	2.1
Space requirements	2.1
Free space around the machine	2.1
Water supply and drains	2.2
Water supply	2.2
Drains	2.2
Electrical requirements	2.3
Main power connection	2.3
Main power outlet	2.3
Power cable	2.3
Electrical specifications	2.4
Installation requirements for power supply	2.4
Fuses	2.5
Power consumption	2.5
Part 3: Pre-installation check list	3.1

Part 1: Transportation

When the processor arrives

Storing the processor before installation

The crated processor will usually be delivered some time before the arrival of the Service Technician. In which case you should prepare an appropriate place indoors to store the crated processor.

The crate

Dimensions and weight

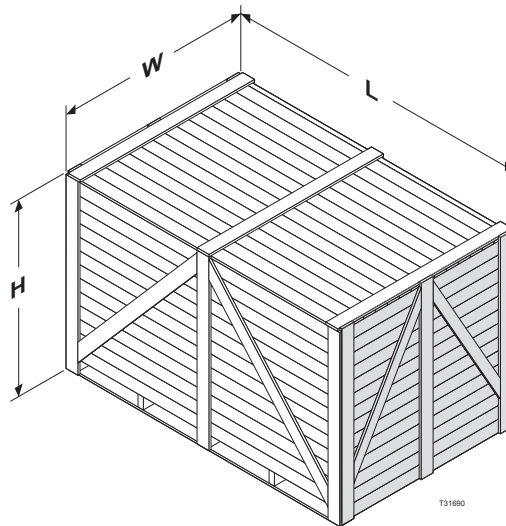

Processor (incl. preheat section)	85	125
Width (W)	1552 mm (61.1")	1952 mm (76.9")
Length (L)	2152 mm (84.7")	2152 mm (84.7")
Height (H)	1500 mm (59.1")	1500 mm (59.1")
Weight, crated (+/- 5%)	950kg (2094 lb)	1230kg (2711.7lb)
Weight, without crate	600kg (1322.8 lb)	840 kg (1851.9 lb)

Preheat section	85	125
Width (W)	1180 mm (46.4")	1180 mm (46.4")
Length (L)	1510 mm (59.4")	1910 mm (75.2")
Height (H)	750 mm (29.5")	750 mm (29.5")
Weight, crated (+/- 5%)	270 kg (595.2 lb)	350 kg (771.6 lb)
Weight, without crate	190 kg (418.9 lb)	250 kg (551.2 lb)

Checking the crate for damage

Check if the crate is damaged at the time of delivery. Take note of the damage before you allow the Service Technician to unpack the processor. Provide a detailed description or take a photograph of the damage.

Report any damage to the crate to the transport company.

Handling the crate

The icons on the crate indicate how to handle the crate during transport and storage:

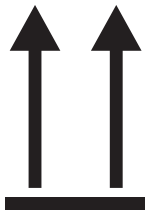

Ensure that the side indicated by the arrows is always up



Handle the crate with care.



Never expose the crate to water, or place it in a high-humidity area.

T31691

Transporting the processor

Lifting the crate

To lift the crate, at least a forklift truck or four persons and a hand powered pallet mover are required.

i Please note that you can only insert the forks of the forklift truck or pallet mover from the side as illustrated below.

! The processor is very heavy equipment. 4 people are needed for removing the processor from the pallet.

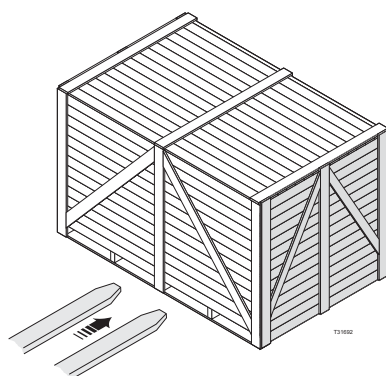

Available width for transport

Depending on the width of the door(s) through which the processor has to be transported to the installation site, the Service Technician may have to perform the actions described in the table below:

	85	125	Then...
	If width of door is ...		
More than	1560 mm (61.4")	1920 mm (75.6")	No action is required as the crated processor can be transported with a fork lift immediately to the installation site.
Less than but more than	1560 mm (61.4")	1920 mm (75.6")	The Service Technician has to unpack the processor according to the descriptions on the next pages. The processor can then be transported on its wheels to the installation site.
Less than	125 cm (49")	145 cm (57")	Arrange for adequate accessibility for transporting the processor to the installation site.

Part 2: Installation requirements

Environmental requirements

Provide a heating and ventilating system capable of maintaining room temperature between 15 and 25°C (59 and 77°F) and relative humidity of max. 80%.

Cleaning facilities

It is essential to have easy access to a sink and a water tap with hot water where rollers, guides, and brushes can be washed.

	Minimum recommended size of the sink
85	100 x 40 cm (39.4 x 15.7")
125	140 x 40 cm (55.1 x 15.7")

Space requirements

Free space around the machine

Decide where the processor will be placed and make sure that the free space around the machine makes servicing possible.

The recommended minimum free space around the machine is specified in the illustrations below:

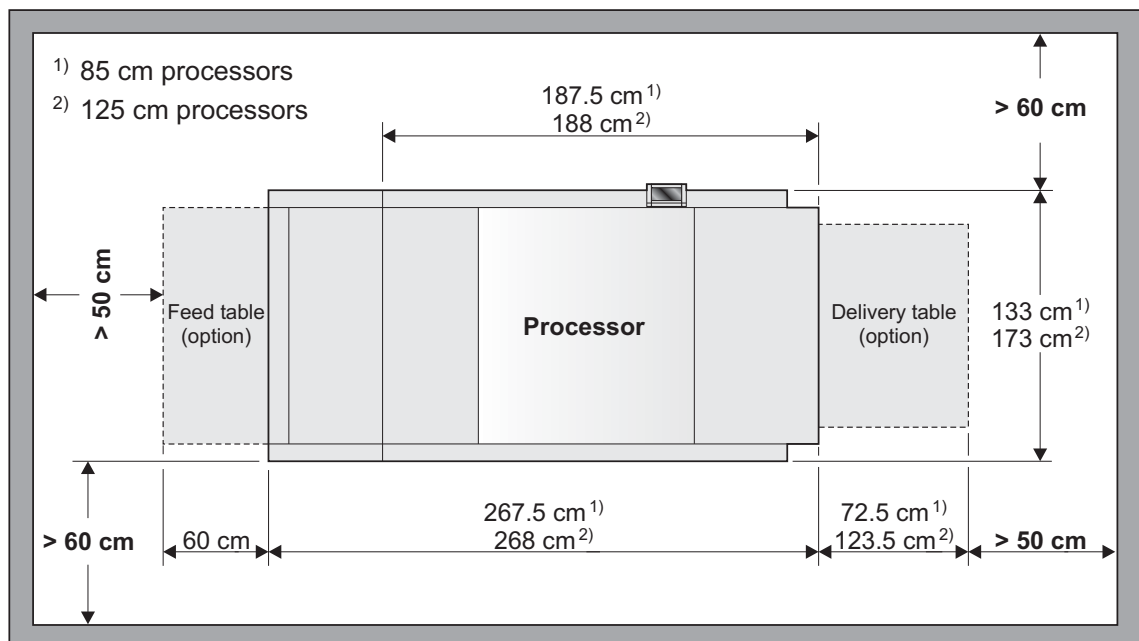

T31685

i For CTP On-line processors, the space requirements at the processor front must be decided separately.

Water supply and drains

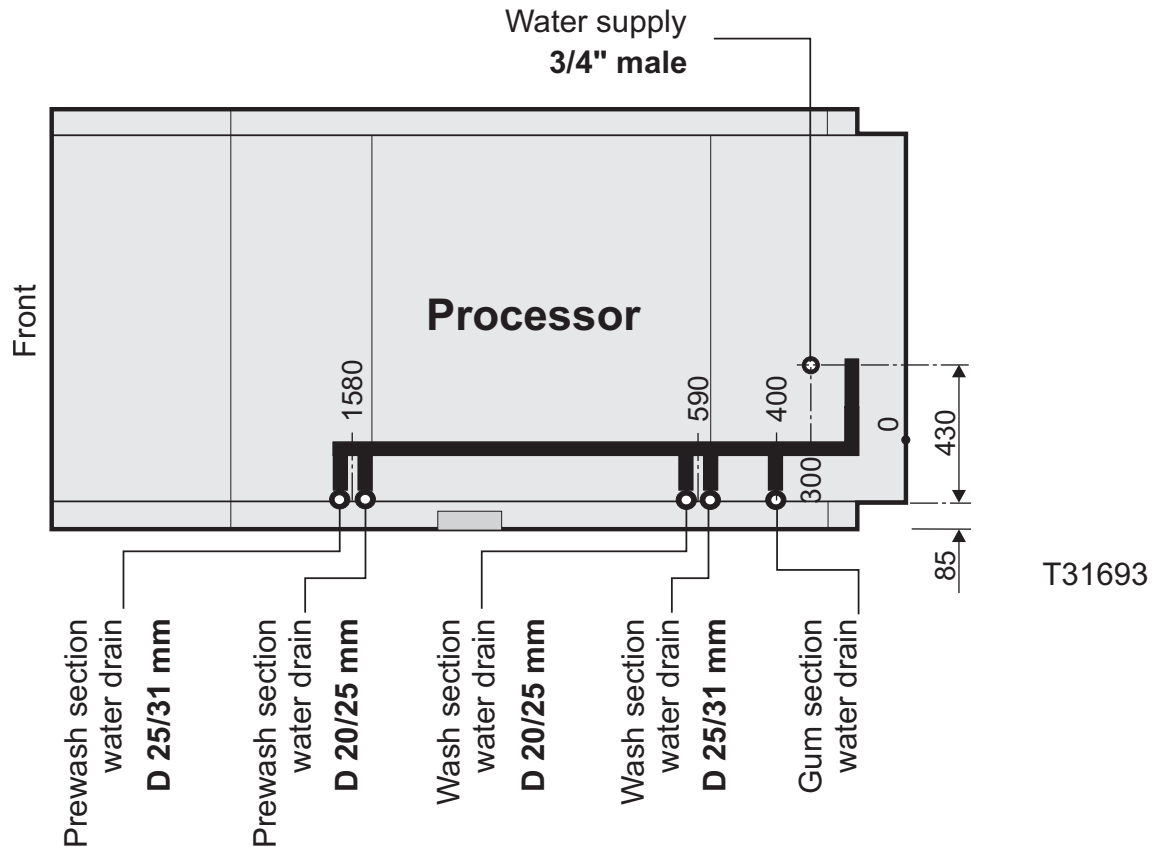

Prepare the installation site for water supply and drain connections according to the illustration above. Please also refer to the processor dimensions described earlier in this document.

Water supply

The water supply connection is located on the rear side of the processor. The supply water pressure must be min. 1 - 6 bar (14.5 - 87 psi). For tap water installations the pressure must be at least 3 bar (42 psi).

Drains

All drain hoses must have a positive fall from the processor to the drain.



Never lead drain hoses from the developer section into a drain, as most developer solutions are strong pollutants. It is also illegal to empty these types of chemicals into the public sewer system.

Under all circumstances local regulations applying to the treatment of (chemical) waste must be followed strictly.

Electrical requirements

 Electrical installation must conform to local regulations and guidelines.

Main power connection

The main power connection is made in the processor's field-wiring box located on the left side of the processor as shown in the illustration below.

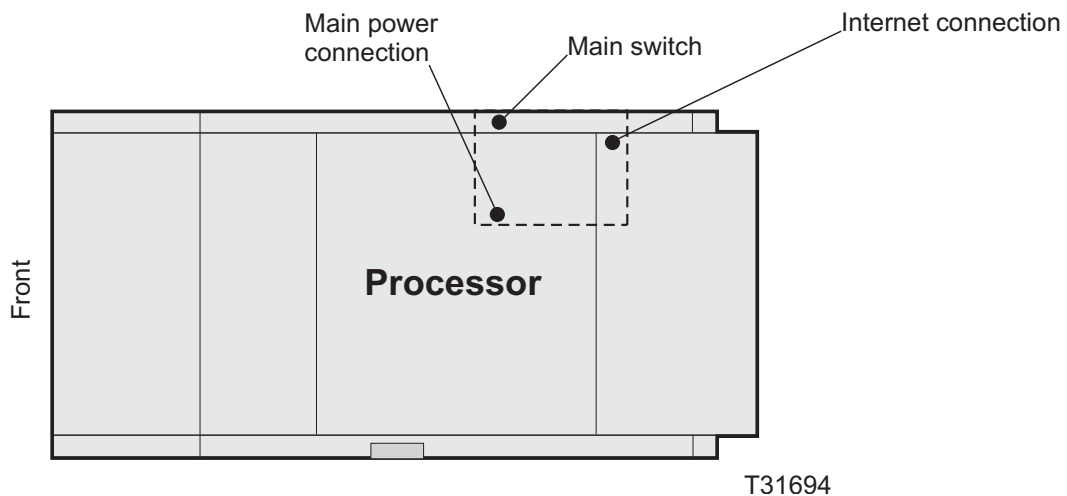



Main power outlet

Provide a main power outlet close to the installation site. The table on the next page indicates the applicable power supply types and to which processor models they apply.

Power cable

The cable for the main power connection is not delivered with the processor. The table on the next side also shows recommended power supply cables.

 When deciding what type of cable to use, you should take into account the chemical resistance (chemicals may leak onto cable) and the mechanical resistance (operator may step onto cable).
The conductors in the power supply cable should be of copper.
Provide for additional cable protection, e.g., cable covers, if cable is exposed to heavier transport such as fork-lift trucks etc.

 The processor is Class 1 equipment. Therefore, the processor must be connected to earth to avoid electrical shocks.
Please be aware of double pole/neutral fusing.

Electrical specifications

Installation requirements for power supply

	Supply / Fuse	Recom. Cable type	85	125
EUR	3W + N + PE, 400 Vac, 3 x 15 A, 50/60 Hz.	Min. 5 x 2.5 mm ² , type H07RNF	•	
	3W + N + PE, 400 Vac, 3 x 25 A, 50/60 Hz.	Min. 5 x 2.5 mm ² , type H07RNF		•
US	3W + PE, 230 Vac, 3 x 30 A, 50/60 Hz.	Min. 4 x 10 AWG, type SJO	•	
	3W + PE, 230 Vac, 3 x 40 A, 50/60 Hz.	Min. 4 x 10 AWG, type SJO		•
JAP	3W + PE, 200 Vac, 3 x 25 A, 50/60 Hz.	Min. 4 x 12 AWG, type SJO	•	
	3W + PE, 200 Vac, 3 x 30 A, 50/60 Hz.	Min. 4 x 10 AWG, type SJO		•

*) Power cord must be in accordance with local regulations.

Fuses



The fuses must have a breaking capacity of min. 100kA.
If using automatic circuit breakers make sure that they are Type D.

Power consumption

	Max power consumption	85	125
EUR/ US	230/400 Vac operation: 9,000 Watt / 30,700 BTU/hour	•	
	230/400 Vac operation: 10,400 Watt / 35,500 BTU/hour		•
	Stand-by: Approx. 500 Watt / 1,710 BTU/hour	•	•
JAP	200 Vac operation: 7,000 Watt / 30,700 BTU/hour	•	
	200 Vac operation: 8,000 Watt / 35,500 BTU/hour		•
	Stand-by: Approx. 500 Watt / 1,710 BTU/hour	•	•
All	Voltage tolerance $\pm 10\%$	•	•

Part 3: Pre-installation check list

Please ask the customer to answer the following questions in order to ensure a trouble-free installation of the processor:

- 1. Delivery of the crate and transport to the installation site** **YES** **NO**
- A. Is there a place indoors where the packing box can be stored temporarily?
- B. Is there a hand-powered pallet mover, a fork-lift truck or any other lifting device available?
- C. Can the crate be transported directly to the installation site?
See minimum width specifications on page 1-3.
- D. Is it sufficient to unpack the processor before it is transported to the installation site?
See minimum width specifications on page 1-3.
- E. Are there other factors (stairs, elevators, corners, obstacles, etc.) which should be taken into account when transporting the crate or processor?
- If so, explain:
-
-
-

2. Power supply

- A. Make a note of the present supply specifications:
- | | | | |
|---------------------|-------------------|-----------------|------|
| No. of Phases | Voltage V | Fused by | Amps |
| Neutral Wire? | Earth Wire? | Frequency | Hz |
- YES** **NO**
- B. Has a connection box been provided to connect the processor to the mains?
- C. Is the customer aware that he/she should provide (or order) all supplies (cables, fuses, etc.) necessary to connect the processor to the mains?
- D. Is there a house electrician available?
- E. Are there any known problems in the building where the processor will be installed?
- If so, explain:
-
-
-

3. Water supply and drain

YES NO

- A. Capacity of air condition/ventilation adequate with regard to BTU as specified on page 2-1? YES NO
- B. Can a hose 3/4" BSP be connected to the water supply tap? YES NO
- C. Is there a large sink (with hot water) for cleaning the equipment? YES NO
- D. Will the processor be connected to a local waste treatment system? YES NO
- E. Is the tap water temperature adjustable? (If recommended by plate supplier). YES NO
- F. Is the supply water pressure min. 6 bar (87 psi)? YES NO
- G. Availability of warm water for cleaning of the processor? YES NO

4. Need for accessories

- A. Remark the input height of the Rinse Gum Unit. Is there a need for leg extenders? YES NO

5. Disposition of the various supplies and equipment on the installation site:

T31695