

Pre-installation Manual



Plate Processor 86

Pre-installation Manual

Plate Processor 86

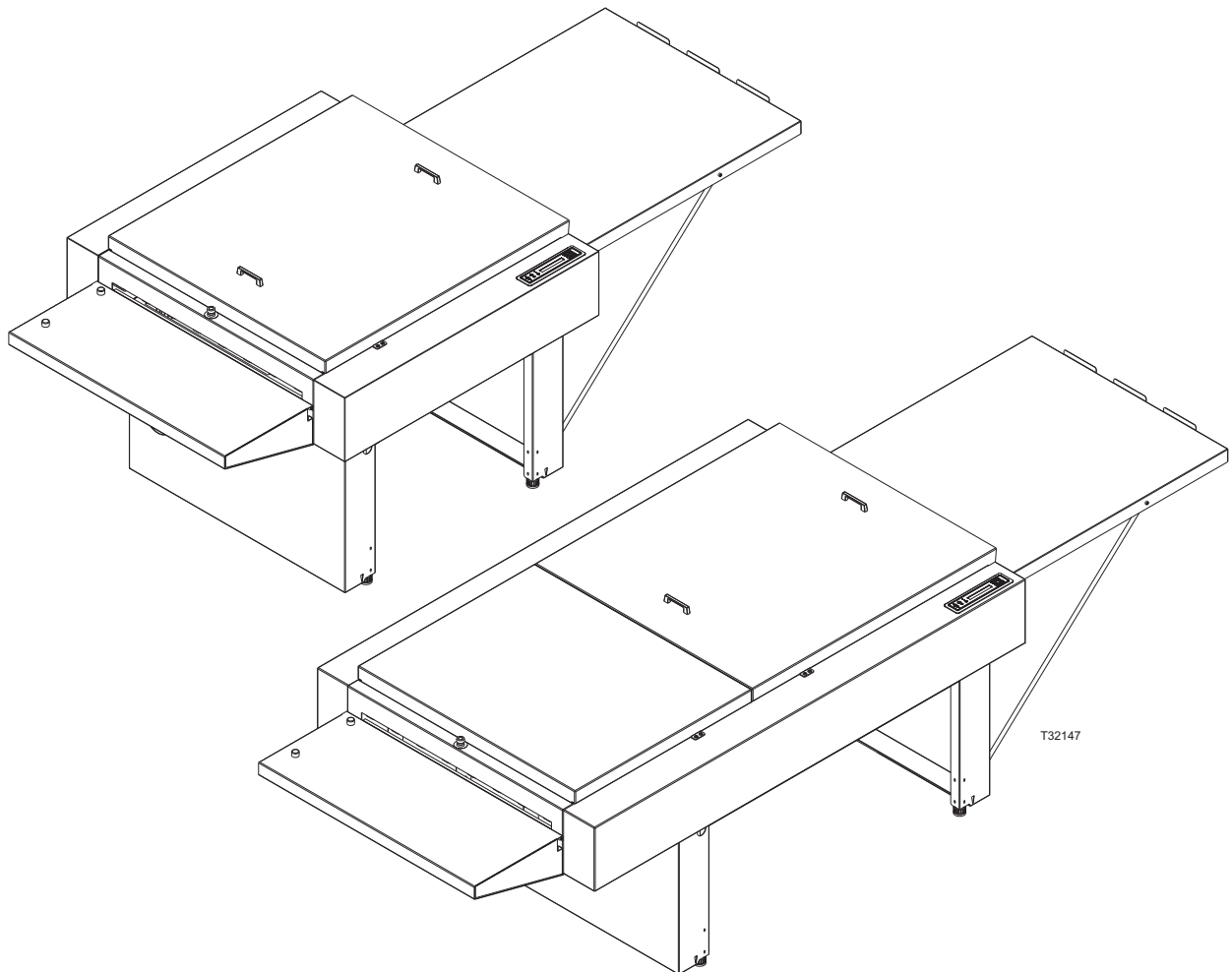

This manual is published by: **GLUNZ & JENSEN A/S**
Haslevvej 13
DK-4100 Ringsted
Denmark
Phone: +45 5768-8181
E-mail: gjhq@glunz-jensen.com
Internet: www.glunz-jensen.com

Copyright © 2012 by GLUNZ & JENSEN A/S.

Part 0: Introduction

Reservations

- This manual was written and illustrated using the best possible information available at the time of publication.
- Any differences between this manual and the equipment reflect improvements introduced after the publication of the manual.
- Changes, technical inaccuracies and typographic errors will be corrected in subsequent editions.
- As a part of our policy of continuous improvement, we reserve the right to alter design and specifications without further notice.

Pre-installation instructions

The instructions in this Pre-installation Manual allow the customer and the Service Technician to prepare the installation site for the plate processor and for the installation itself.

- Never install the processor in explosive environments.
- It is the responsibility of the owner and operator/s of the processor that the installation is made in accordance with local regulations, and by engineers authorized to carry out plumbing and electrical installations.
- The manufacturer cannot be held responsible for any damage caused by incorrect installation of the processor.



Only qualified Service Technicians are allowed to unpack and install the equipment.



When preparing the installation site please take into consideration that this equipment is for restricted access locations only!



Please download the Service and User's manuals from G&J home page www.glunz-jensen.com before the installation of the processor.

Notes, cautions, and warnings !

Throughout the manual warnings, cautions, and notes are written in bold like the example below:

 **Electrical installation must conform to local regulations and guidelines.**



Symbol	Meaning	Explanation
	Note	The operator should observe and/or act according to the information in order to obtain the best possible function of the equipment.
	Caution	The operator must observe and/or act according to the information in order to avoid any mechanical or electrical damage to the equipment.
	Warning	The operator must observe and/or act according to the information in order to avoid any personal injury.

Table of contents

Part 0: Introduction	0-3
Reservations	0-3
Pre-installation instructions	0-3
Notes, cautions, and warnings !	0-4
Part 1: Transportation	1-1
When the processor arrives	1-1
Storing the processor before installation	1-1
The crate	1-1
Dimensions and weight.	1-1
Checking the crate for damage.	1-2
Handling the crate	1-2
Transporting the processor.	1-3
Lifting the crate	1-3
Available width for transport	1-3
Part 2: Installation requirements	2-1
Environmental requirements	2-1
Cleaning facilities	2-1
Necessary tools and software requirements	2-1
Space requirements	2-2
Free space around the machine	2-2
Processor dimensions (thermal/conventional).	2-3
Processor dimensions (polymer).	2-4
Water supply and drains	2-5
Water supply	2-6
Drains.	2-6
Electrical requirements	2-7
Main power connection.	2-7
Main power outlet	2-7
Power cable.	2-7
Electrical specifications (thermal/conventional).	2-8
Installation requirements for power supply	2-8
Fuses	2-8
Power consumption	2-8
Electrical specifications (polymer).	2-9
Installation requirements for power supply	2-9
Fuses	2-9
Power consumption	2-9
Part 3: Pre-installation checklist	3-1

Part 1: Transportation

When the processor arrives

Storing the processor before installation

The crated processor will usually be delivered some time before the arrival of the service technician. In which case you should prepare an appropriate place indoors to store the crated processor.

The crate

Dimensions and weight

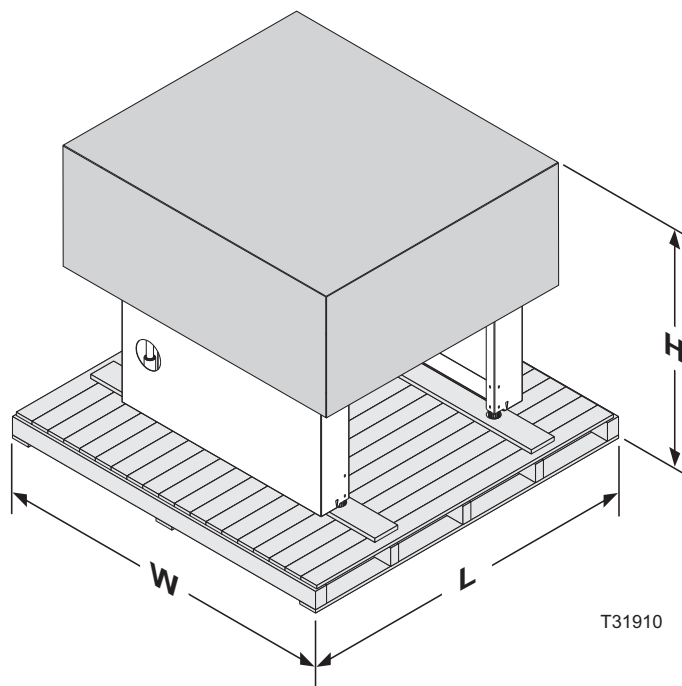

	Thermal/Conventional	Polymer
Length (L)	1340 mm (52.3")	2140 mm (84.3")
Width (W)	1420 mm (55.9")	1420 mm (55.9")
Height (H)	1270 mm (50")	1270 mm (50")
Weight, crated	approx. 305 kg (672 lb)	approx. 430 kg (948 lb)*
Weight, processor	approx. 235 kg (331 lb)	approx. 307 kg (677 lb)*
*) w.o. tables, w. 3 brushes)		

Checking the crate for damage

Check if the crate is damaged at the time of delivery. Take note of the damage before you allow the service technician to unpack the processor. Provide a detailed description or take a photograph of the damage.



Report any damage to the crate to the transport company.

Handling the crate

The icons on the crate indicate how to handle the crate during transport and storage:

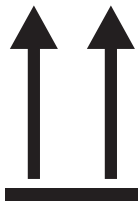

Ensure that the side indicated by the arrows is always up



Handle the crate with care.



Never expose the crate to water, or place it in a high-humidity area.



Do not stack the crates.

T31691

Transporting the processor

Lifting the crate

The processor is supplied wrapped in a foil in a cardboard crate on a wooden pallet. To lift the crate a fork-lift truck or two persons and a hand powered pallet mover are required.



The processor is very heavy equipment. Four people are needed for removing the processor from the pallet. The processor will be delivered with two pipe bars for lifting it off the pallet. It is not possible to lift the processor off the pallet using a fork lift truck or a pallet mover.

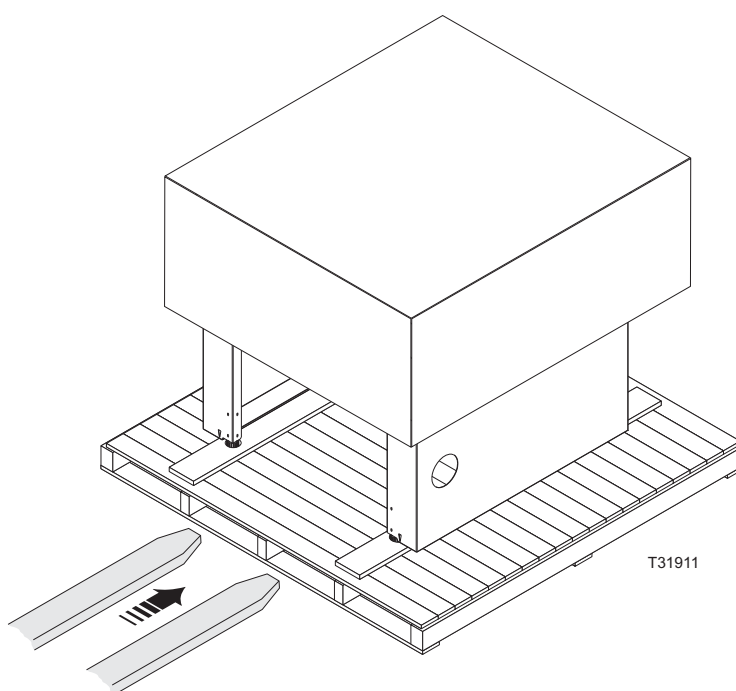

Available width for transport

Depending on the width of the door(s) through which the processor has to be transported to the installation site, the service technician may have to perform the actions described in the table below:

If width of the door is...		Then...
Thermal/Conventional	Polymer	
> 1340 mm	> 2140 mm	No action is required as the crated processor can be transported immediately to the installation site.
1250 - 1340 mm	2000 - 2140 mm	The Service Technician has to unpack the processor.
< 1250 mm	< 2000 mm	The Service Technician has to unpack and strip down the processor.

Part 2: Installation requirements



This processor must be installed in restricted access locations only.

Environmental requirements

Provide a heating and ventilating system capable of maintaining room temperature between 15 and 25°C (59 and 77°F) and relative humidity on max. 80%.
For heat emission see "Power consumption" on the pages 2-8 and 2-9.

Cleaning facilities

It is essential to have easy access to a sink and a water tap with hot water where rollers, guides, and brushes can be washed.

Minimum recommended size of the sink
100 x 40 cm (39.4 x 15.7")

Necessary tools and software requirements

- The Remote Enabling system - standard at delivery of the processor.
- PC for online connection to the processor.
- Ethernet cable (G&J part number 10064789) delivered with the processor.

Space requirements

Free space around the machine

Decide where the processor shall be placed and make sure that the free space around the machine makes servicing possible.

The recommended minimum free space around the machine is specified in the illustration below:

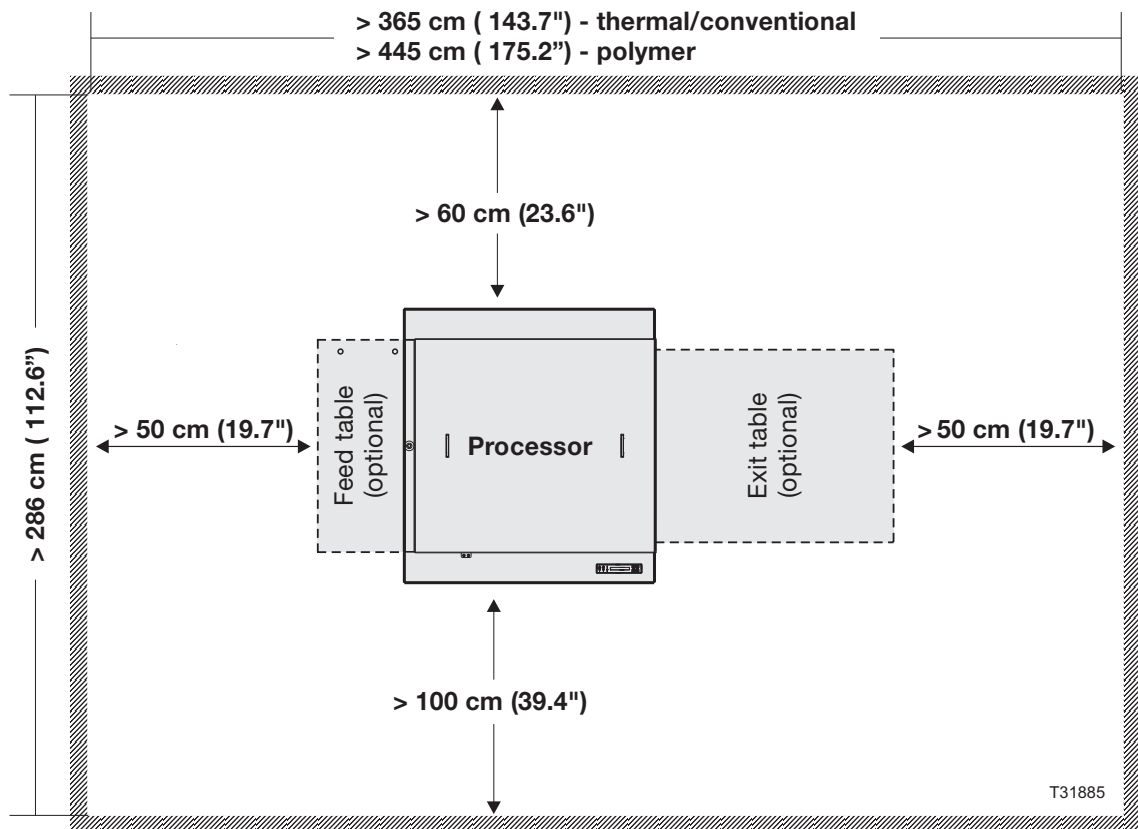

For CTP On-line processors the space requirements at the processor front has to be decided separately.

Processor dimensions (thermal/conventional)

Side view

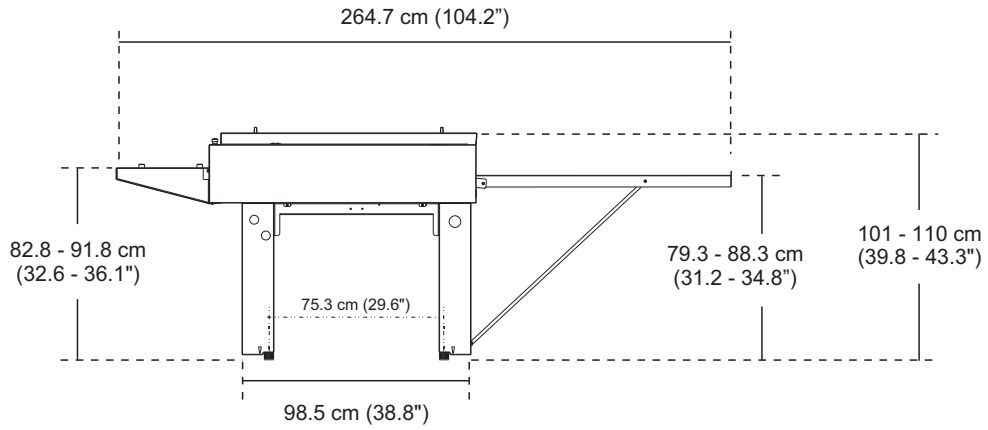

Top view

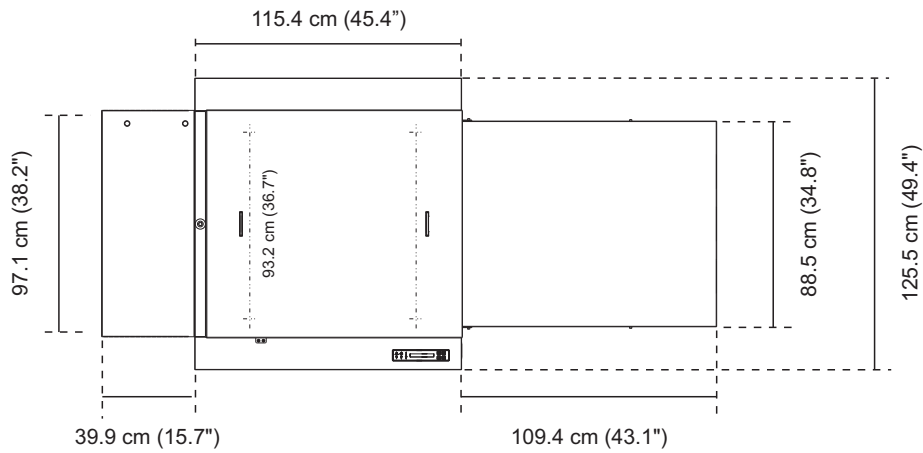

T31886

Processor dimensions (polymer)

Side view

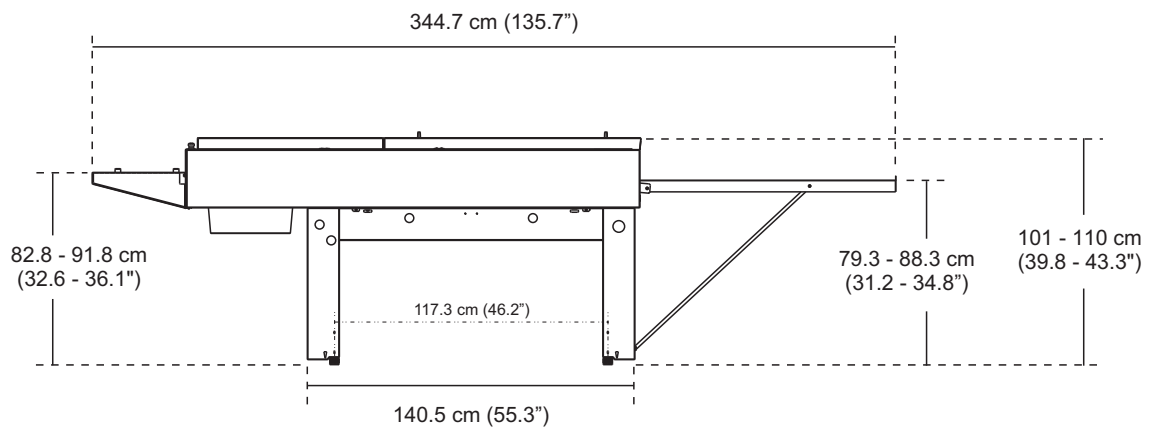

Top view

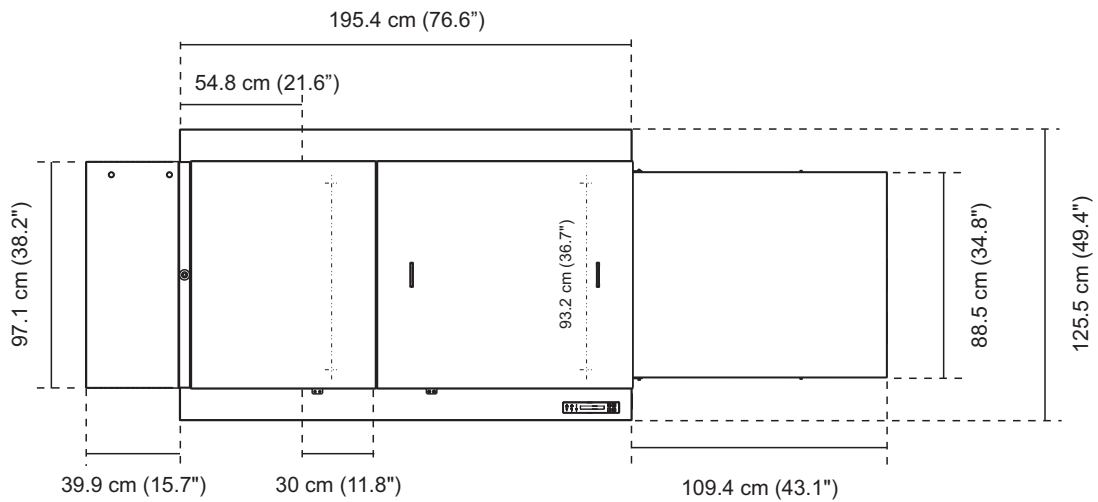

T31886

Water supply and drains

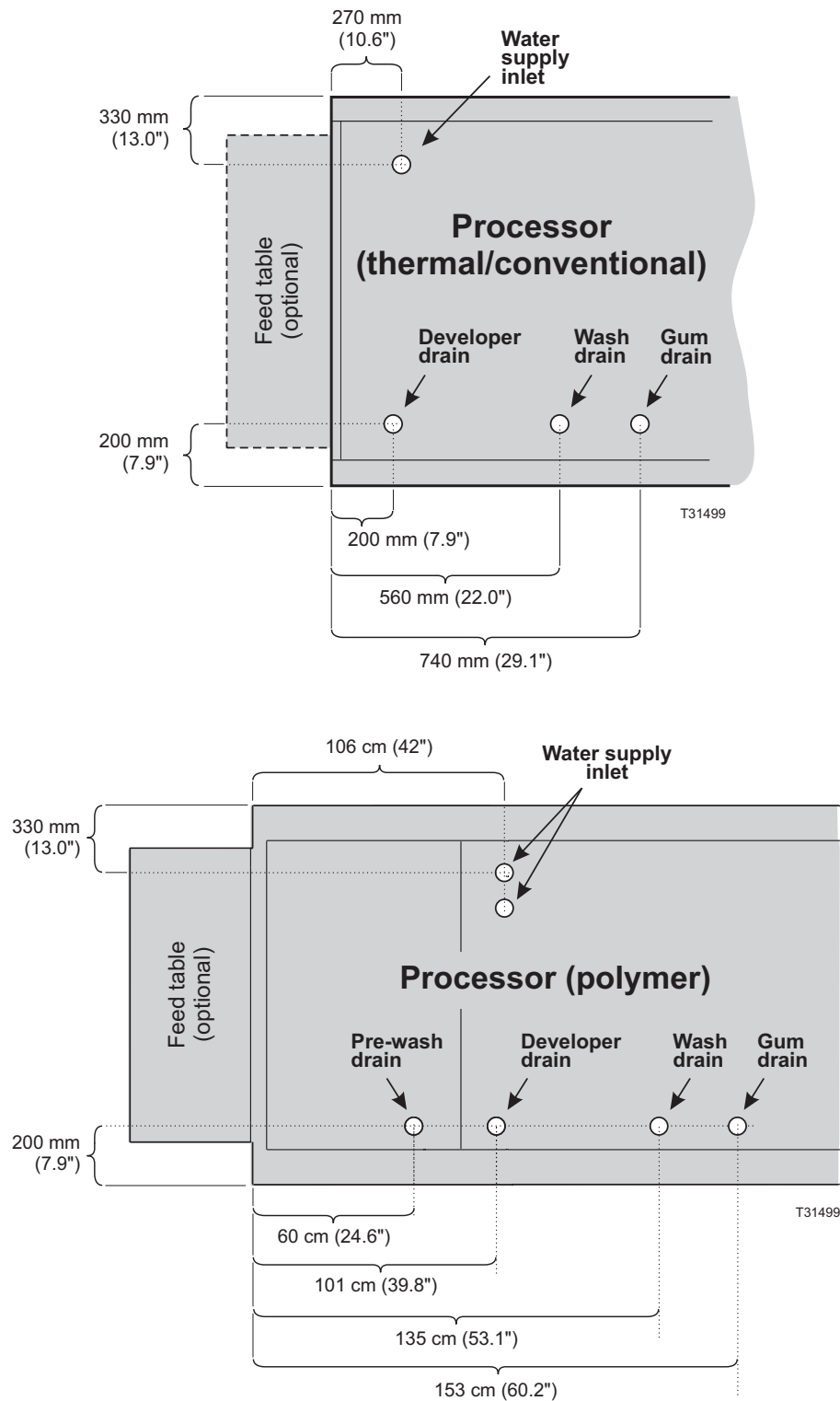

Prepare the installation site for water supply and drain connections according to the illustration above. Please also refer to the processor dimensions described earlier in this document.

Water supply

The water supply connection is located on the left front side underneath the processor. The supply water pressure must be min. **1 - 6 bar (15 - 87 psi)**.

Drains

- The developer drain must be led to a waste container.
- The pre-wash/wash drain can be led to public drain. Refer to the local regulations.
- The gum must be drained into a container and recirculated.



When establishing central reception systems for waste chemicals, copper or brass should not be used in the drainage system as the chemicals involved are highly corrosive. Therefore plastic or rubber is recommended. Check with the chemicals supplier for details.



Many countries have strong regulations regarding disposal of waste. Refer to the local regulations when making preparations for drains.

Electrical requirements

 Electrical installation must conform to local regulations and guidelines.

Main power connection

The main power connection is made in the processor's plug located at the back of the right fender as shown in the illustration below.

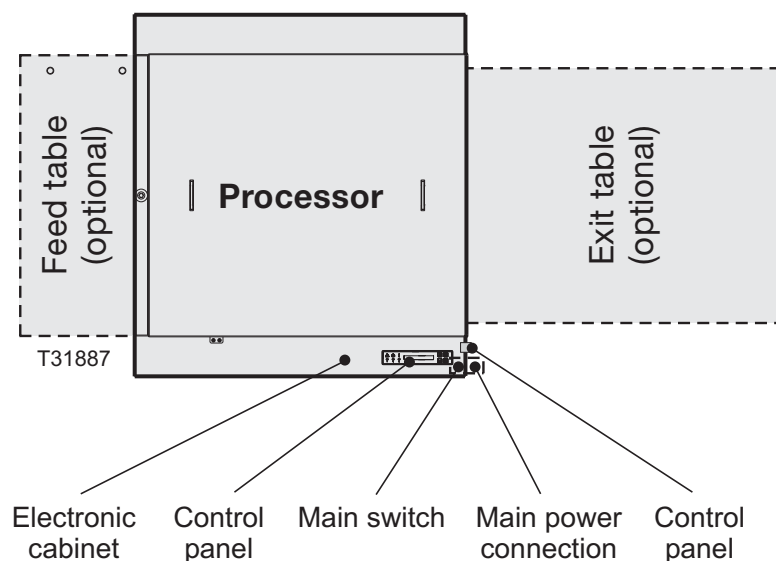



Main power outlet

Provide a main power outlet close to the installation site. The table on the next page indicates the applicable power supply types and to which processor models they apply.

Power cable

The cable for the main power connection is included. See the power supply table on the next page. The table also shows recommended power supply cables for processors delivered without cable.

-  When deciding what type of cable to use take into account the chemical resistance (chemicals may leak onto cable) and the mechanical resistance (operator may step onto cable).
The conductors in the power supply cable should be of copper.
Provide for additional cable protection, e.g. cable covers, if cable is exposed to heavier transport such as fork-lift trucks etc.
-  The processor is Class 1 equipment. Therefore, the processor must be connected to earth to avoid electrical shocks.
Please be aware of double pole/neutral fusing.

Electrical specifications (thermal/conventional)

Installation requirements for power supply



Specifications on the processor's name plate is the actual input current and will thus not be identical to below mentioned.

	Supply/fuse	Recommended cable type
EUR	Single Phase, 1W + N + PE 230 V / 1x16 Amps, 50-60 Hz	Min. 3 x 1,5 m ² , type H03VV-F
US	Single Phase, 2W + PE 230 V / 2x15 Amps, 50-60 Hz	Min. 3 x 16 AWG, type SJO
JAP	Single Phase, 2W + PE 200 V / 2x15 Amps, 50-60 Hz	Min. 3 x 16 AWG, type SJO
All	Voltage tolerance ± 10%	

Fuses



The fuses must have a breaking capacity of min. 100kA.
If using automatic circuit breakers make sure that they are Type D.

Power consumption

	Power consumption at ...
EUR/ US	230 VAC operation: approx. 1.76 kWh (6000 BTU/hour)
	Stand-by: approx. 0.06 kWh (200 BTU/hour)

Electrical specifications (polymer)

Installation requirements for power supply

 Specifications on the processor's name plate is the actual input current and will thus not be identical to below mentioned.

	Supply/fuse	Recommended cable type
EUR	Single Phase, 1W + N + PE 230 V / 1x16 Amps, 50-60 Hz	Min. 3 x 1,5 m ² , type H03VV-F
US	Single Phase, 2W + PE 230 V / 2x20 Amps, 50-60 Hz	Min. 3 x 16 AWG, type SJO
JAP	Single Phase, 2W + PE 200 V / 2x15 Amps, 50-60 Hz	Min. 3 x 16 AWG, type SJO
All	Voltage tolerance ± 10%	

Fuses

 The fuses must have a breaking capacity of min. 100kA.
If using automatic circuit breakers make sure that they are Type D.

Power consumption

	Power consumption at ...
EUR/ US	230 VAC operation: approx. 2.7 kWh (9000 BTU/hour)
	Stand-by: approx. 1 kWh (3400 BTU/hour)

Part 3: Pre-installation checklist

Please ask the customer to answer the following questions in order to ensure a trouble-free installation of the processor:

- | 1. Delivery of the crate and transport to the installation site | YES | NO |
|---|--------------------------|--------------------------|
| A. Is there a place indoor where the crated processor can be stored temporarily? | <input type="checkbox"/> | <input type="checkbox"/> |
| B. Is there a hand-powered pallet mover, a fork-lift truck or any other lifting device available? | <input type="checkbox"/> | <input type="checkbox"/> |
| C. Can the crate be transported directly to the installation site?
<i>See minimum width specifications on page 1-3.</i> | <input type="checkbox"/> | <input type="checkbox"/> |
| D. Is it sufficient to unpack the processor before it is transported to the installation site? <i>See minimum width specifications on page 1-3.</i> | <input type="checkbox"/> | <input type="checkbox"/> |
| E. Are there other factors (stairs, elevators, corners, obstacles, etc.) which should be taken into account when transporting the crate or processor? | <input type="checkbox"/> | <input type="checkbox"/> |
| If so, explain: | | |
| | | |
| | | |
| | | |

2. Power supply

- | | | |
|--|--------------------------|--------------------------|
| A. Make a note of the present supply specifications: | | |
| No. of Phases | Voltage V | Fused by Amps |
| Neutral Wire? | Earth Wire? | Frequency Hz |
| | YES | NO |
| B. Has a connection box been provided to connect the processor to the mains? | <input type="checkbox"/> | <input type="checkbox"/> |
| C. Is the customer aware that he/she should provide (or order) all supplies (cables, fuses, etc.) necessary to connect the processor to the mains? | <input type="checkbox"/> | <input type="checkbox"/> |
| D. Is there a house electrician available? | <input type="checkbox"/> | <input type="checkbox"/> |
| E. Are there any known problems in the building where the processor will be installed? | <input type="checkbox"/> | <input type="checkbox"/> |
| If so, explain: | | |
| | | |
| | | |
| | | |
| | | |

	YES	NO
3. Water supply and drain		
A. Capacity of air condition/ventilation adequate with regard to BTU/hour as specified on pages 2-8 and 2-9?	<input type="checkbox"/>	<input type="checkbox"/>
B. Can a hose 3/4"RG-11.5NH or 3/4"x3/4" be connected to the water supply tap?	<input type="checkbox"/>	<input type="checkbox"/>
C. Is there a large sink (with hot water) for cleaning the equipment?	<input type="checkbox"/>	<input type="checkbox"/>
D. Will the processor be connected to a local waste treatment system?	<input type="checkbox"/>	<input type="checkbox"/>
E. Is the tap water temperature adjustable? (If recommended by plate supplier).	<input type="checkbox"/>	<input type="checkbox"/>
F. Does the supply water pressure lie between 1 and 6 bar (15 and 87 psi)?	<input type="checkbox"/>	<input type="checkbox"/>
G. Availability of warm water for cleaning of processor?	<input type="checkbox"/>	<input type="checkbox"/>

4. Disposition of the various supplies and equipment on the installation site:

A large rectangular area filled with a fine grid pattern, intended for drawing or taking notes regarding the disposition of supplies and equipment on the installation site.