



# Pre-installation Guide

## Low Chemistry Unit 85

---

▶ **IMPORTANT**

Please follow the instructions in this guide when preparing the installation site prior to arrival and installation of the equipment.

---

June 14th, 2024  
Edition BA, Part No 10066333  
English (en-us) Original version

*(Blank)*

# About this manual

This manual applies to the Plate Processor **Low Chemistry Unit 85**.

This manual is published by:

**Glunz & Jensen A/S**

Selandia Park 1

DK-4100 Ringsted

Denmark

Phone: +45 57 68 81 81

E-mail: [gj@glunz-jensen.com](mailto:gj@glunz-jensen.com)

Internet: [www.glunz-jensen.com](http://www.glunz-jensen.com)

Copyright © June, 2024 by Glunz & Jensen A/S

# Table of Contents

|  |           |
|--|-----------|
| <b>About this manual</b> .....                           | <b>3</b>  |
| <b>Table of Contents</b> .....                           | <b>4</b>  |
| <b>Introduction</b> .....                                | <b>5</b>  |
| Reservations .....                                       | 5         |
| Introduction .....                                       | 5         |
| Notes, Cautions and Warnings! .....                      | 5         |
| <b>Transportation</b> .....                              | <b>7</b>  |
| When the equipment arrives .....                         | 7         |
| Storing of the equipment prior to the installation ..... | 7         |
| The crate .....  | 7         |
| Crate Dimensions .....                                   | 7         |
| Weight .....   | 8         |
| Checking the crate for damage .....                      | 8         |
| Handling the crate .....                                 | 8         |
| Lifting the crate .....                                  | 9         |
| Required width of passage and doorways .....             | 9         |
| <b>Installation requirements</b> .....                   | <b>11</b> |
| Heating and ventilation .....                            | 11        |
| Cleaning facilities .....                                | 11        |
| Space requirements .....                                 | 12        |
| Free space around the equipment .....                    | 12        |
| Dimensions .....   | 13        |
| Connections .....  | 13        |
| Water supply and drains .....                            | 14        |
| Drains .....   | 14        |
| Electrical requirements .....                            | 15        |
| Main power connection .....                              | 15        |
| Main power outlet .....                                  | 15        |
| Power cable .....  | 15        |
| Electrical specifications .....                          | 16        |
| Power supply requirements .....                          | 16        |
| Power consumption .....                                  | 16        |
| <b>Checklist</b> .....                                   | <b>17</b> |

# Introduction

## Reservations



- This manual was written and illustrated using the best possible information available at the time of publication.
- Any differences between this manual and the equipment reflect improvements introduced after the publication of the manual.
- Changes, technical inaccuracies and typographic errors will be corrected in subsequent editions.
- As a part of our policy of continuous improvement, we reserve the right to alter design and specifications without further notice.

## Introduction

The instructions in this Pre-installation Guide help the customer and the Service Technician to prepare the installation site for the arrival and installation of the equipment.

## Notes, Cautions and Warnings!

Notes, cautions, and warnings in this manual are used and categorized as described below:

| Symbol  | Meaning        | Explanation   |
|---|----------------|---|
|  | <b>NOTE</b>    | The operator should observe and/or act according to the information in order to obtain the best possible function of the equipment.       |
|  | <b>CAUTION</b> | The operator must observe and/or act according to the information in order to avoid any mechanical or electrical damage to the equipment. |
|  | <b>WARNING</b> | The operator must observe and/or act according to the information in order to avoid any personal injury.                                  |



*(blank page)*

# Transportation

## When the equipment arrives

### Storing of the equipment prior to the installation

The equipment will usually be delivered some time before the arrival of the service technician. Provide for an appropriate place indoor to store the crated equipment until the service technician arrives.

## The crate

### Crate Dimensions

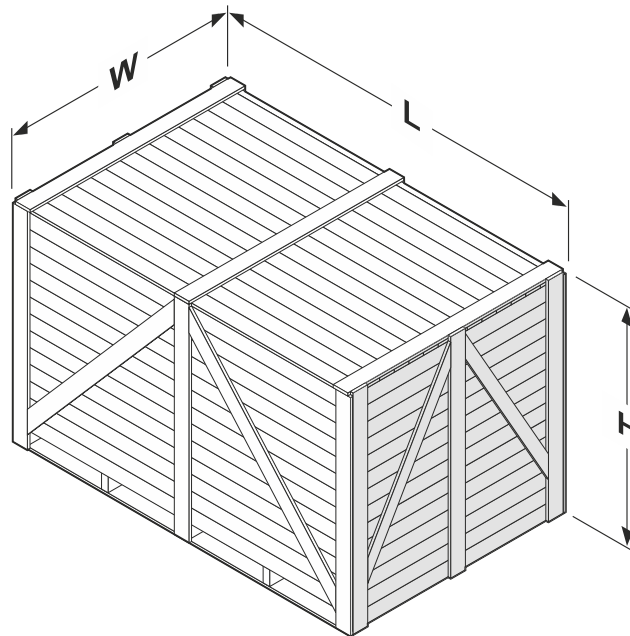

|            | Low Chemistry Unit<br>85 |
|------------|--------------------------|
| Length (L) | 1600 mm (63.0")          |
| Width (W)  | 1420 mm (55.9")          |
| Height (H) | 1263 mm (49.7")          |

## Weight

|               | Low Chemistry Unit<br>85 |
|---------------|--------------------------|
| With crate    | 365 kg (805 lbs)         |
| Without crate | 255 kg (562 lbs)         |

## Checking the crate for damage

Upon receipt of the machinery, check if the crate is damaged on delivery at the customer's address. Make notes of any damages, before opening the crate. Provide a detailed description and take a photograph of the damage.

Report any damage of the crate to the shipping company and notify the insurance agent, if appropriate, before the mishandled package is open.

Check the Tilt watch and the Shock watch label that the red mark has not appeared and compare their serial numbers with those on the box label whether they match.

## Handling the crate

The icons on the crate indicate how to handle the crate during transport and storage:



Ensure that the side indicated by the arrows is always up.



Handle the crate with care



Never expose the crate to water, or place it in a high-humidity area.



Do not stack the crates.



Do not tilt the crate.



## Lifting the crate

The equipment is supplied in a wooden crate on a pallet.

A forklift truck or two persons and a hand powered pallet mover are required for lifting the crate on arrival and for lifting the equipment off the pallet.



**WARNING:** The equipment is very heavy equipment.  
It is only possible to lift the equipment off the pallet using a forklift truck or a pallet mover.



**CAUTION:** Make sure to provide a forklift designed and adequate for lifting a crate of the size and weight as specified in this manual.

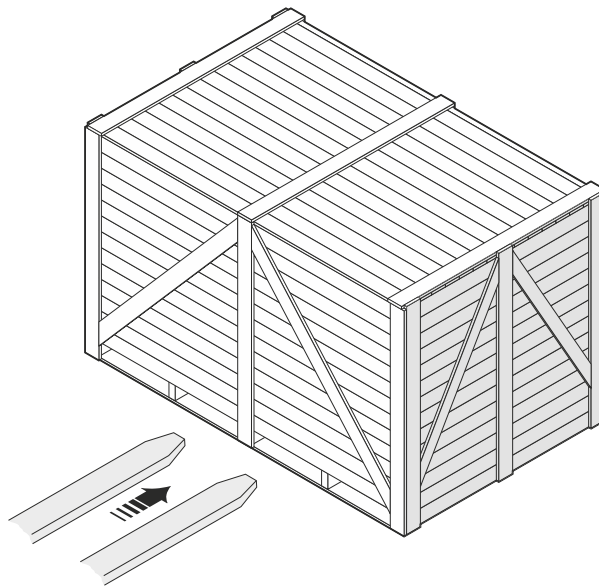

## Required width of passage and doorways

Depending on the width of the passage- and doorways through which the equipment has to be transported to the installation site, the service technician may have to perform the actions described in the table below:

| If width of the doorway is ... | 85                                 | Then ...   |
|--------------------------------|------------------------------------|--|
| <b>More than</b>               | 1620 mm (63.8")                    | No action is required as the crated equipment can be transported immediately to the installation site. |
| <b>Less than but more than</b> | 1620 mm (63.8")<br>1360 mm (53.5") | The Service Technician has to unpack the equipment.  |
| <b>Less than</b>               | 1360 mm (53.5")                    | The Service Technician has to remove panels and perhaps disassemble parts of the equipment.            |



*(blank page)*

# Installation requirements

## Heating and ventilation

Provide a heat and ventilation system capable of maintaining room temperature between 15°C (59°F) and 25°C (77°F) and a relative humidity (non condensing) of min. 40% and max. 80%.

For heat emission see "Power consumption" on page 16.

## Cleaning facilities

It is essential to have easy access to a sink and a water tap with hot water where rollers, guides, and brushes can be washed.

|                       | Minimum recommended size of the sink |
|-----------------------|--------------------------------------|
| Low Chemistry Unit 85 | 100 × 40 cm (39.4 × 15.7")           |

## Space requirements

### Free space around the equipment

Decide for a proper installation site for the equipment and make sure that the free space around the equipment makes servicing possible.

The recommended minimum free space around the equipment is specified in the next illustration.



**CAUTION:** For CTP On-line, the space requirements at the equipment front has to be decided separately.

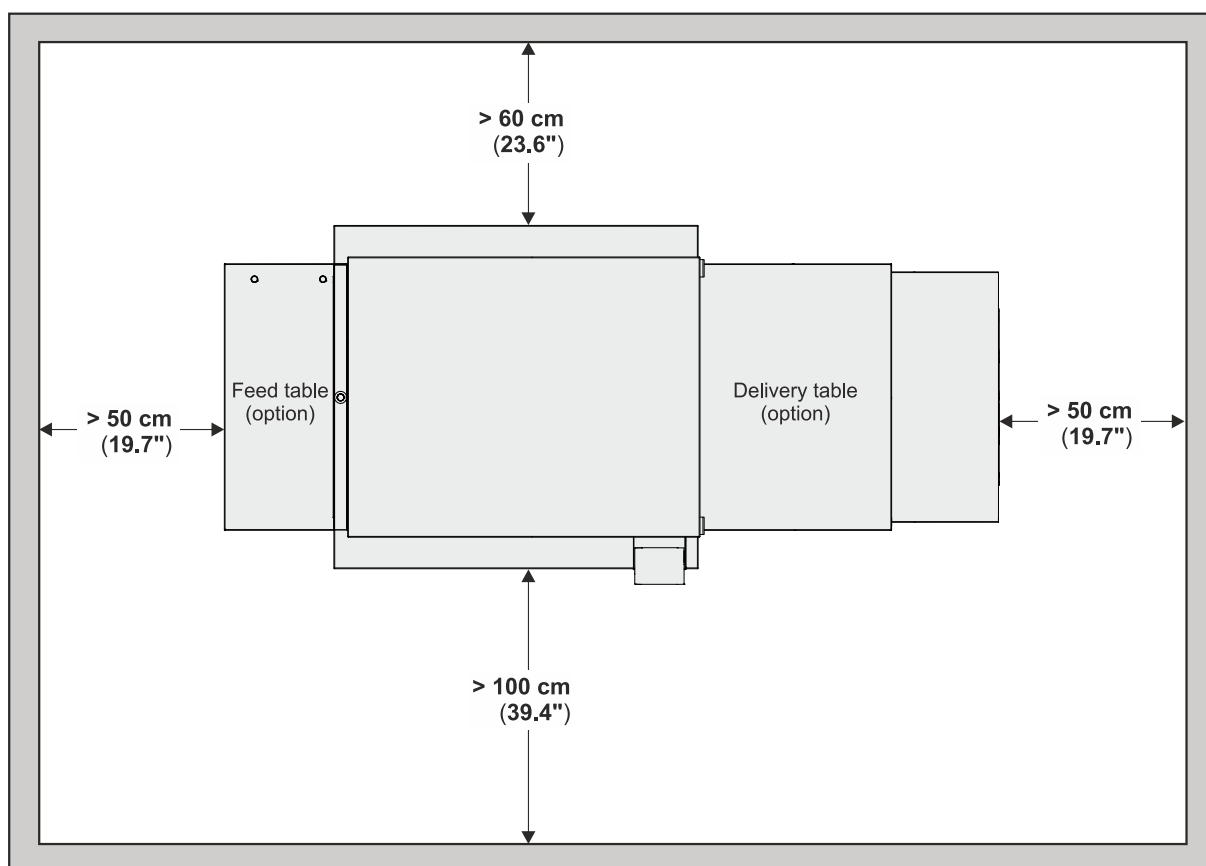

# Dimensions

Side view

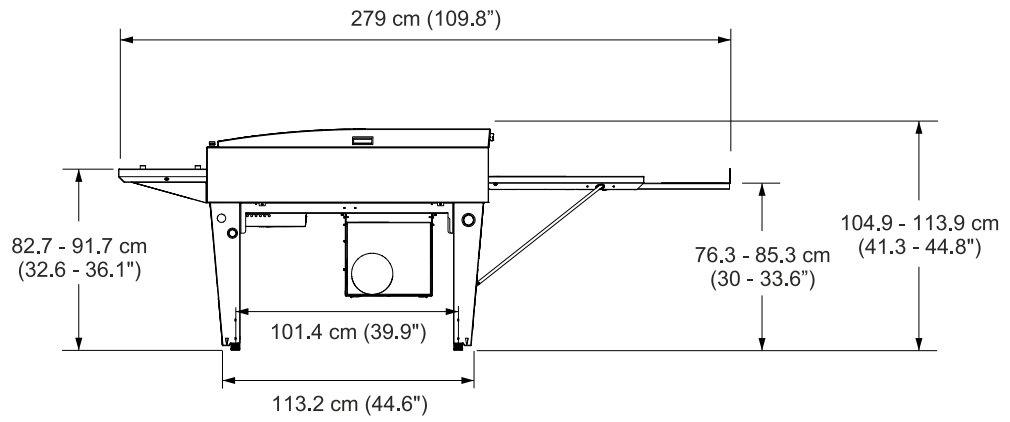

Top view

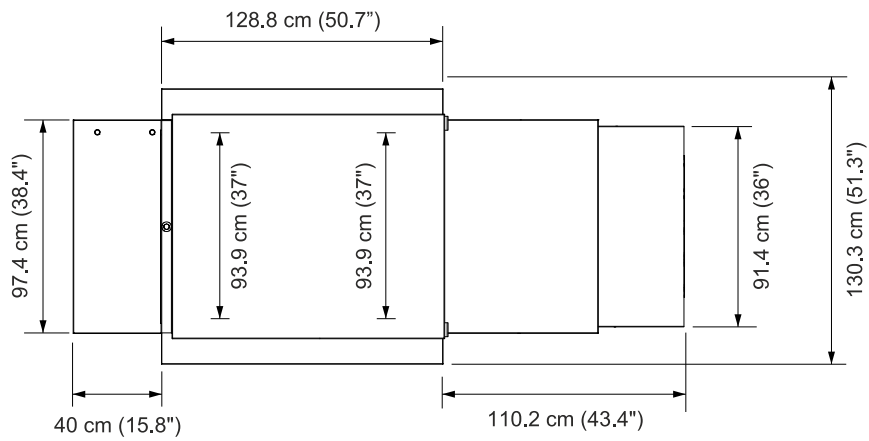

# Connections

## Water supply and drains

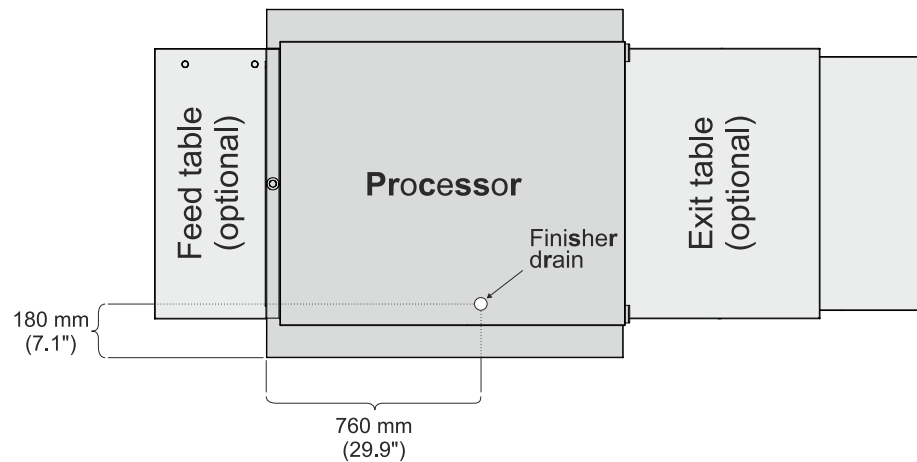

### Drains

All drain hoses must have a positive fall from the equipment to the drain.



**NOTE:** Never lead chemicals into public drainage systems as most chemical solutions are strong pollutants.

Contact your supplier of chemicals if you need information about the chemical solution with regard to personal safety.

Refer to local authorities for information regarding environmental protection and disposal of waste chemicals.

## Electrical requirements



**WARNING:** Electrical installation, all cabling and cabling connections, fusing and isolation must conform to local and/or national regulations and guidelines.

### Main power connection

The main power connection must be made to the main connector located on the right-rear side of the equipment.

### Main power outlet

Provide an mains power-outlet with an electrical plug lockout close to the installation site. The table showing "Power supply requirements" on the next page indicates the applicable power supply types.

### Power cable



**NOTE:** The cable for the main power connection is included with the equipment.



**WARNING:** The equipment is Class 1 equipment. Therefore, the equipment must be connected to earth to avoid electrical shocks.

Please be aware of double pole/neutral fusing.



**CAUTION:**

The conductors in the power supply cable should be of copper.

When deciding what type of cable to use, also consider the chemical resistance (chemicals may leak onto cable) and the mechanical resistance (operator may step onto cable).

Provide for additional cable protection, e.g. cable covers, if cable is exposed to heavier transport such as fork-lift trucks etc.

## Electrical specifications

### Power supply requirements



**CAUTION:** The requirements below are specifications for preparing the installation protection. The fuses/circuit breakers must be prepared according to local regulations, and with adequate capacity as specified here. The circuit breakers must be suitable for inventor operation.



**NOTE:** Specifications on the equipment's name plate is the actual input current and will thus not be identical to below mentioned.

|     | Supply *                          | Fuses and cables types<br>Low Chemistry Unit<br>85                             |
|-----|-----------------------------------|--|
| EUR | 1W + N + PE,<br>230 VAC, 50/60 Hz | Fused by 1 × 16 Amps<br>Cable type: Min. 3 × 1.5 mm <sup>2</sup> , type H03W-F |
| US  | 2W + PE,<br>230 VAC, 50/60 Hz     | Fused by 2 × 20 Amps<br>Cable type: Min. 3 × 14 AWG, type SJO                  |
| JAP | 2W + PE,<br>200 VAC, 50/60 Hz     | Fused by 2 × 20 Amps<br>Cable type: Min. 3 × 14 AWG, type SJO                  |

\*) Voltage tolerance ± 10%



**NOTE:** The power cable(s) must be in accordance with local regulations.



**WARNING:** Please be aware of double pole/neutral fusing.



**CAUTION:** The fuses must have a breaking capacity of min. 100 kA. If using automatic circuit breakers make sure that they are Type D.



**CAUTION:** If a circuit breaker of type ELCB, RCCB, or GFCI is used where leakage to ground is detected, the trip sensitivity must be 300 mA.



**WARNING:** High leakage current! Earth connection essential before connecting supply.



**WARNING:** Connection to mains shall be permanent connection. Connection via wall plug isn't allowed.

### Power consumption

|                                    | Low Chemistry Unit<br>85 |
|------------------------------------|--------------------------|
| In operate, per phase (±10%), max. | 2700 W (9000 BTU)        |
| In stand-by                        | 900 W (3000 BTU)         |



# Checklist

The customer should answer the following questions in order to ensure a trouble-free installation of the equipment and send the completed pre-installation checklist to the service technician who is responsible for coordination of the installation.

|    |  |                       |                       |
|----|--|-----------------------|-----------------------|
| 1. | <b>Delivery of the crate and transport to the installation site</b>  | <b>YES</b>            | <b>NO</b>             |
|    | A. Is there a place indoor where the crated equipment can be stored temporarily?   | <input type="radio"/> | <input type="radio"/> |
|    | B. Is there a hand-powered pallet mover, a forklift truck or any other lifting device available? Please refer to "Transportation" on page 7.                             | <input type="radio"/> | <input type="radio"/> |
|    | C. Can the crate be transported directly to the installation site? See "Required width of passage and doorways" on page 9.   | <input type="radio"/> | <input type="radio"/> |
|    | D. Is it necessary to unpack the equipment before it is transported to the installation site? See "Required width of passage and doorways" on page 9.                    | <input type="radio"/> | <input type="radio"/> |
|    | E. Are there other factors (stairs, elevators, corners, obstacles, etc.) which should be taken into account when transporting the equipment?<br>If YES, please describe: | <input type="radio"/> | <input type="radio"/> |
|    | _____  |                       |                       |
|    | _____  |                       |                       |
| 2. | <b>Power supply</b>  | <b>YES</b>            | <b>NO</b>             |
|    | A. Make a note of the present supply specifications:   |                       |                       |
|    | Number of phases: _____ Neutral wire? <input type="radio"/>  |                       |                       |
|    | Voltage (V): _____ Earth wire? <input type="radio"/>   |                       |                       |
|    | Fused by (Amps): _____   |                       |                       |
|    | Frequency (Hz): _____  |                       |                       |
|    | B. Has a suitable, isolated connection box been provided to connect the equipment to the mains?  | <input type="radio"/> | <input type="radio"/> |
|    | C. Has the customer provided/ordered all supplies (cables, fuses, etc.) necessary to connect the equipment to the mains?   | <input type="radio"/> | <input type="radio"/> |
|    | D. Is there a house electrician available?   | <input type="radio"/> | <input type="radio"/> |
|    | E. Are there any known problems in the building where the equipment will be installed?<br>If YES, please describe which:   | <input type="radio"/> | <input type="radio"/> |
|    | _____  |                       |                       |
|    | _____  |                       |                       |

- |    |  | YES                   | NO                    |
|----|--|-----------------------|-----------------------|
| 3. | <b>Water supply and drains</b>   |                       |                       |
| A. | Can a hose $\frac{3}{4}$ " BSP be connected to the water supply tap?         | <input type="radio"/> | <input type="radio"/> |
| B. | Is there a large sink (with hot water) for cleaning the equipment?           | <input type="radio"/> | <input type="radio"/> |
| C. | Will the equipment be connected to a local waste treatment system?           | <input type="radio"/> | <input type="radio"/> |
| D. | Is the tap water temperature adjustable? (If recommended by plate supplier). | <input type="radio"/> | <input type="radio"/> |
| E. | Is the supply water pressure min. 6 bar (87 psi)?                            | <input type="radio"/> | <input type="radio"/> |
| F. | Is warm water for cleaning of the equipment available?                       | <input type="radio"/> | <input type="radio"/> |

- |    |   | YES                   | NO                    |
|----|---|-----------------------|-----------------------|
| 4. | <b>Heating and ventilation</b>  |                       |                       |
| A. | Is the capacity of the air condition/ventilation system adequate with regard to the BTU as specified in "Power consumption" on page 16? | <input type="radio"/> | <input type="radio"/> |

5. **Comments and questions**

---

---

---

---