

# Pre-installation Manual



PlateWriter™ 3000



# Pre-installation Manual

---

## PlateWriter™ 3000

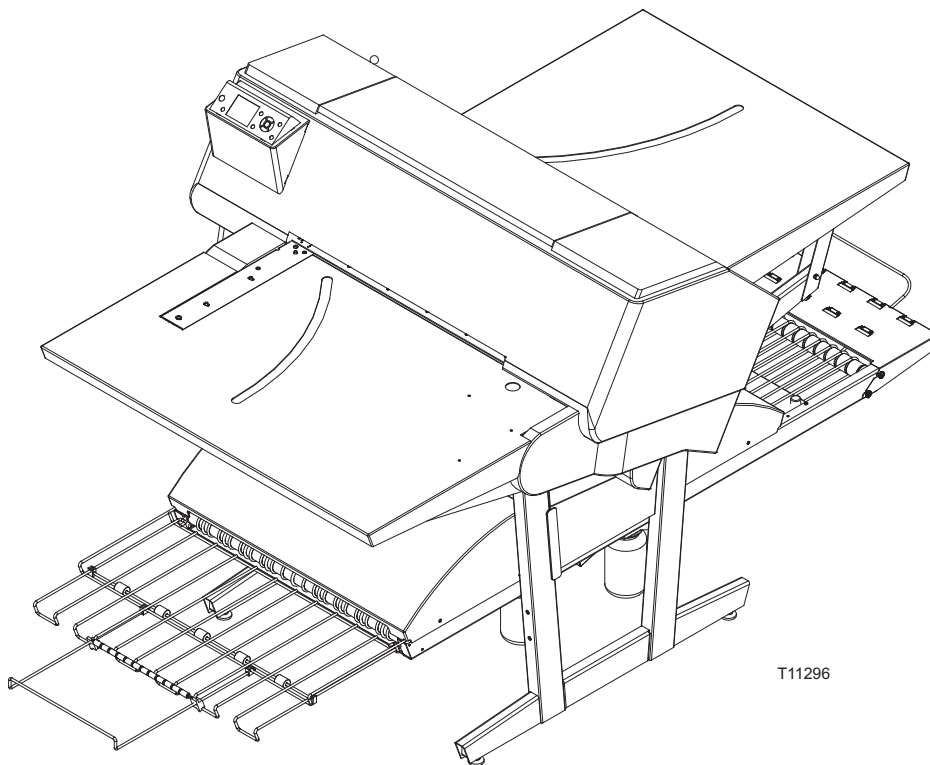

T11296

Edition AA, August 2014  
This book has part No 10076381

This manual is published by: **GLUNZ & JENSEN A/S**  
Selandia Park 1  
DK-4100 Ringsted  
Denmark  
Phone:+45 57 68 81 81  
E-mail: [gjhq@glunz-jensen.com](mailto:gjhq@glunz-jensen.com)  
Internet: [www.glunz-jensen.com](http://www.glunz-jensen.com)

© 2014 Glunz & Jensen A/S. All rights reserved.

# Table of contents

<b>Part 1: Introduction</b> . . . . .	<b>1-1</b>
About this manual . . . . .	1-1
Intended use of this manual . . . . .	1-1
Reservations . . . . .	1-1
Important . . . . .	1-1
Unintended use of the equipment. . . . .	1-1
Installation . . . . .	1-1
Notes, cautions, and warnings !. . . . .	1-2
<b>Part 2: When the crates arrive</b> . . . . .	<b>2-1</b>
Storing the crates . . . . .	2-1
Crate dimensions and weights . . . . .	2-1
Checking for damage . . . . .	2-1
Transporting the crates . . . . .	2-2
Handling the crates . . . . .	2-2
Lifting the crates . . . . .	2-2
Available doorway width for transport. . . . .	2-2
<b>Part 3: Site requirements</b> . . . . .	<b>3-1</b>
General requirements . . . . .	3-1
Environmental requirements . . . . .	3-1
Cleaning facilities. . . . .	3-1
Space requirements . . . . .	3-2
PlateWriter dimensions. . . . .	3-2
Free space around the PlateWriter . . . . .	3-4
RIP workstation . . . . .	3-5
Location . . . . .	3-5
Network connection . . . . .	3-5
Power supply . . . . .	3-6
Main power connection. . . . .	3-6
Power outlet requirements. . . . .	3-7
Power consumption . . . . .	3-7
Power cables . . . . .	3-8
<b>Part 4: Pre-installation checklist</b> . . . . .	<b>4-1</b>



# Part 1: Introduction

## About this manual

### Intended use of this manual

- This manual describes how to prepare the installation site for the installation of the PlateWriter 3000 system. The procedures described in this manual require a reasonable level of technical skill and access to the proper tools.

### Reservations

- This manual was written and illustrated using the best possible information available at the time of publication.
- Any differences between this manual and the equipment reflect improvements introduced after the publication of the manual.
- Changes, technical inaccuracies and typographical errors will be corrected in subsequent editions.
- As a part of our policy of continuous improvement, we reserve the right to alter design and specifications without further notice.

## Important

### Unintended use of the equipment

Glunz & Jensen A/S do not take any responsibility for any damage or accidents caused by unintended use of the equipment:

- As the equipment is certified by accredited test laboratory (UL International Demko A/S) it is absolutely prohibited to make any modifications, electrical nor mechanical, of the equipment. If however this prohibition is disregarded, Glunz & Jensen's warranty will no longer apply and the certification labels for UL, C-UL, and CE certification of the equipment shall be removed as the certification will no longer apply to the equipment.

### Installation

- Never install the equipment in explosive environments.
- It is the responsibility of the owner and operator/s of the equipment, that the installation is made in accordance with local regulations, and by engineers authorized to carry out electrical installations.
- Installation must be performed only by service technicians who are trained in installing the equipment.
- The manufacturer cannot be held responsible for any damage caused by incorrect installation of this equipment.

## Notes, cautions, and warnings !

Throughout the manual notes, cautions, and warnings are written in bold like the example below:



**Always replace a fuse with one of the same size and rating as the old one.**

Symbol	Meaning	Explanation
	<b>Note</b>	The operator should observe and/or act according to the information in order to obtain the best possible function of the equipment.
	<b>Caution</b>	The operator must observe and/or act according to the information in order to avoid any mechanical or electrical damage to the equipment.
	<b>Warning</b>	The operator must observe and/or act according to the information in order to avoid any personal injury.



# Part 2: When the crates arrive

## Storing the crates

The crates containing the PlateWriter system will usually arrive some time before the arrival of the Service Technician. In such a case you should prepare an appropriate place indoors to store the crates.

### Crate dimensions and weights

Below are the dimensions and weights of the crates included with the delivery:

	L x W x H	Weight
Imaging unit (1)	1356 x 667 x 1218 mm (53.4 x 26.3 x 48")	approx. 100 kg (220 lbs)
Finishing unit, tables, stand etc. (2)	1950 x 950 x 1200 mm (76.8 x 37.4 x 47.2")	approx. 234 kg (516 lbs)

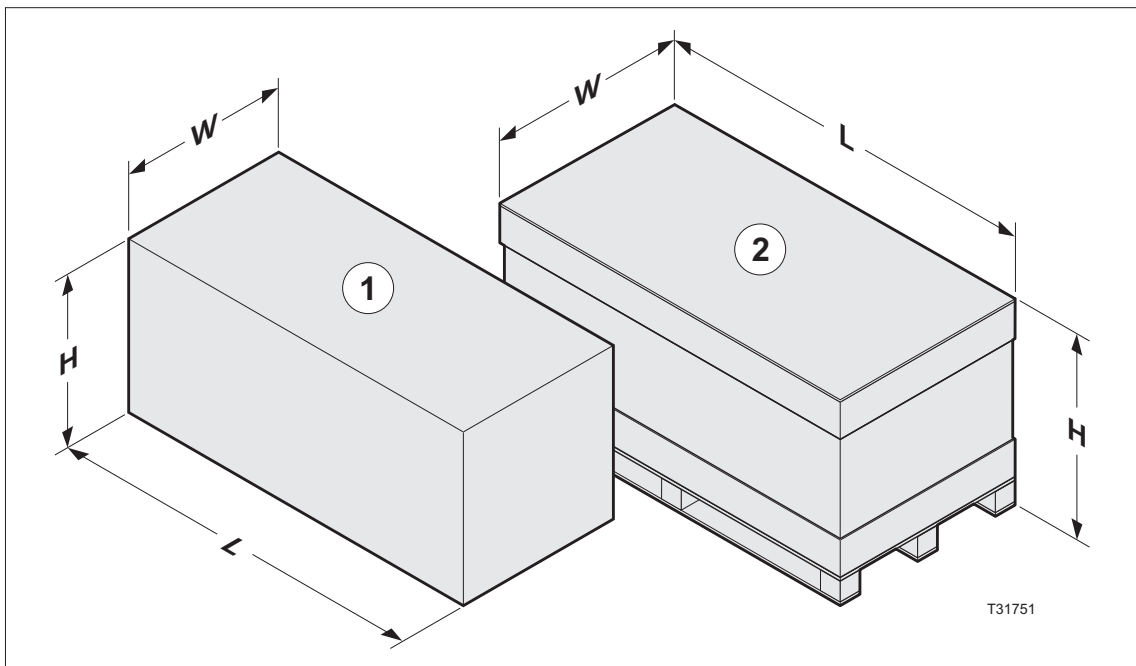

### Checking for damage

When receiving the crates do the following:

- Check if the crates are damaged at the time of delivery.
- Report any damage to the crate(s) to the transport company.
- Take notes of the damage before you unpack the crates. Provide a detailed description and/or take a photograph of the damage.

## Transporting the crates

### Handling the crates

The icons on the crates indicate how to handle them during transport and storage:



### Lifting the crates

To lift the crates, at least a fork-lift truck or two persons and a hand-powered pallet mover are required.

### Available doorway width for transport

If the width of the door(s) through which the crates have to be transported to the installation site are too narrow, you will have to unpack the crates and transport all parts to the installation site separately.



Two or more persons are required for this operation.

# Part 3: Site requirements

## General requirements

### Environmental requirements

Provide a heating and ventilating system capable of maintaining room temperature between 20 and 24°C (68 and 75°F) and relative humidity between 40 and 80%.

For heat emission see "Power consumption" on the page 3-6.

### Cleaning facilities

We recommend that you have easy access to a sink and a water tap with hot water for cleaning purposes.

The minimum recommended size of the sink is 90 x 40 cm (35.4 x 15.8").

## Space requirements

### PlateWriter dimensions

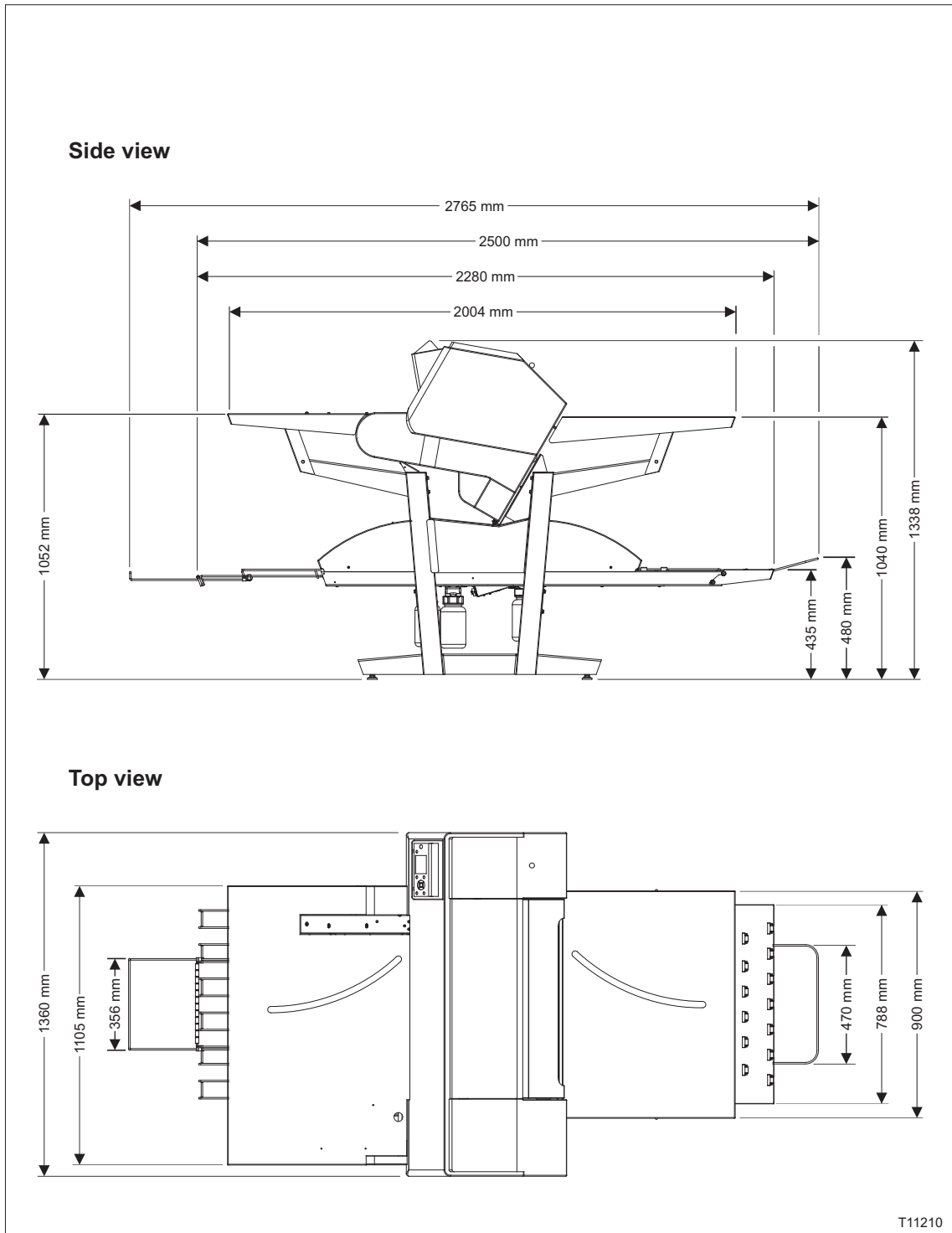

## Free space around the PlateWriter

Decide where the unit shall be placed and make sure that the free space around it makes operation and servicing possible.

Be aware of the following:

- **Liquid Dot** cartridges need to be replaced on left side of the unit.
- Access to cables is required at the both sides of the unit.
- Plates are loaded onto the input table from the front right of the unit.
- After imaging the plate must be placed on the finishing unit's transport belts from the lower front of the unit.
- After finishing, the plate must be removed from the finishing unit's exit tray at the lower back of the unit.

The recommended minimum free space around the machine is specified in the illustration below:

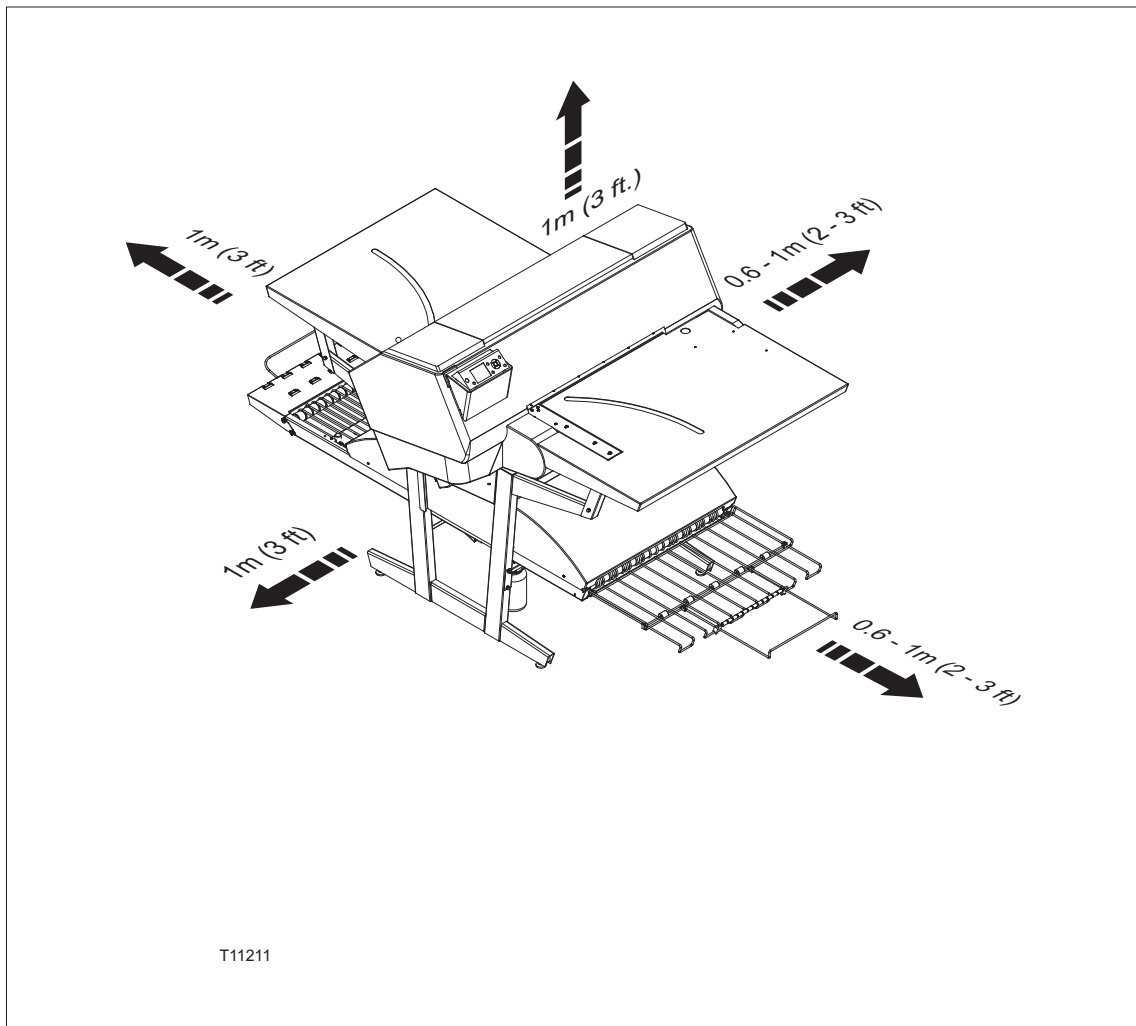

## RIP workstation

### Location

The RIP workstation must be placed within 3 m (9 ft) from the imaging unit as they need to be connected using the enclosed USB-cable.



To avoid any harmful communication interference between the RIP workstation and the imaging unit, it is recommended not to use a USB-cable longer than 3 m (9 ft).

### Network connection

If the RIP workstation is going to be connected to a local network (LAN) make sure to provide a network connection nearby.

## Power supply



Electrical installation must conform to local rules and regulations.

### Main power connection

The PlateWriter system requires three main power connections, one for the PlateWriter itself, one for the finishing unit and print bed (the print bed is powered from the finishing unit), and one for the RIP workstation.

The PlateWriter main power inlet is located at the right side of the equipment and finishing unit main power inlet is located at the left side of the equipment (see illustration below).

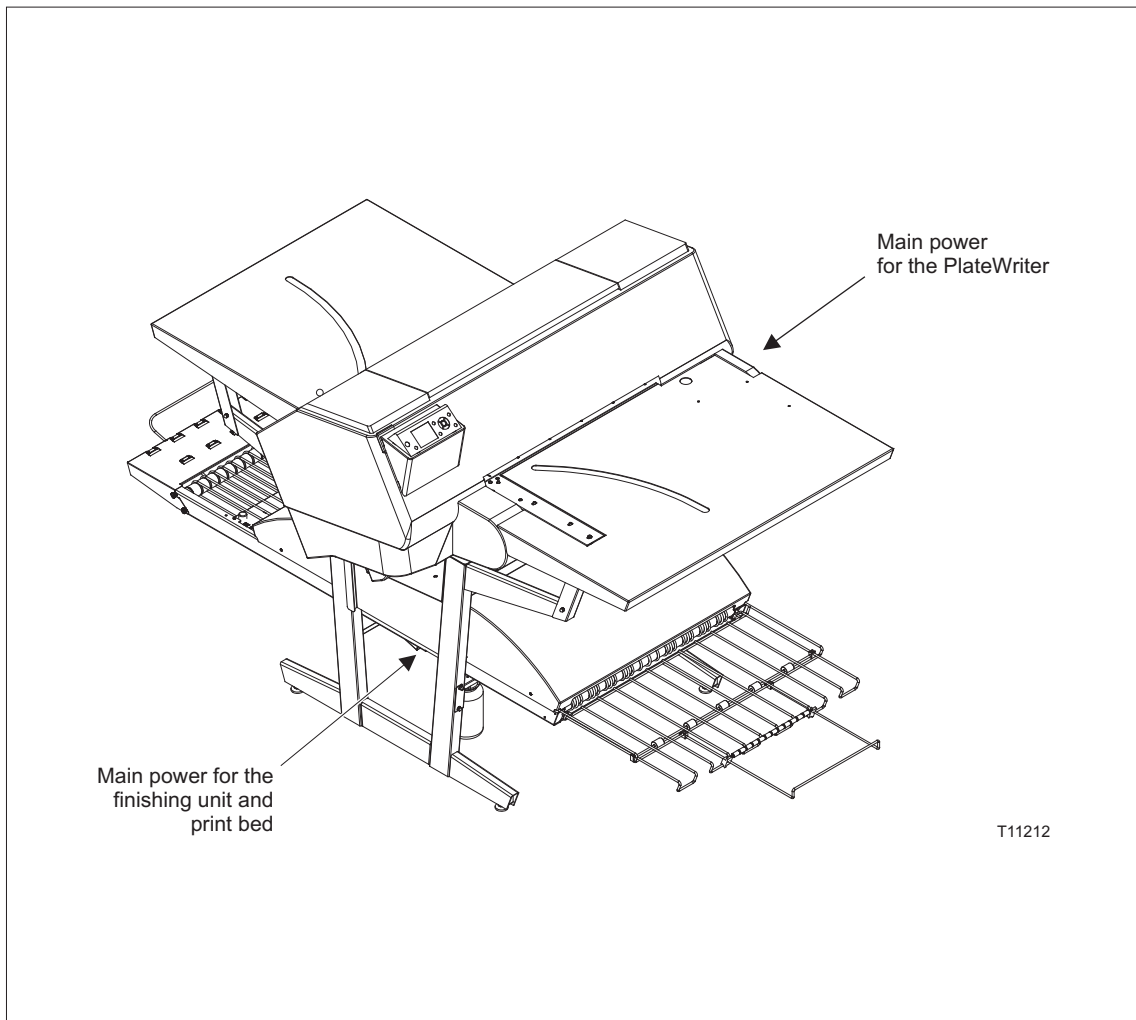

## Power outlet requirements

If not already present, main power outlets should be installed in the room where the unit will be situated. Max. distance to the machine 2 m (6 ft.).



**The units are Class 1 appliances and must be connected to earthed mains socket outlets.**



**These units require a short circuit protection device in the building installation as specified below.**



**Specification on the unit's name plate is the actual input current and will thus not be identical to below mentioned.**

	Unit	Supply/fuse
EUR	Printer unit	Single Phase, 1W + N + PE, 230V, 50 - 60 Hz Fuse: Max. 16A, type D01, gL/gG, interrupting capacity 50kA
	Finishing unit	Single Phase, 1W + N + PE, 230V, 50 - 60 Hz Fuse: Max. 16A, type D01, gL/gG, interrupting capacity 50kA
	RIP workstation	Single Phase, 1W + N + PE, 230V, 50 - 60 Hz Fuse: Max. 16A, type D01, gL/gG, interrupting capacity 50kA
USA	Printer unit	Single Phase, 1W + N + PE, 115V, 50 - 60 Hz Fuse: Max. 20A, class G or CC branch circuit, interrupting capacity 100kA
	Finishing unit	Single Phase, 2W + PE, 230V, 50 - 60 Hz Fuse: Max. 20A, class G or CC branch circuit, interrupting capacity 100kA
	RIP workstation	Single Phase, 1W + N + PE, 115V, 50 - 60 Hz Fuse: Max. 20A, class G or CC branch circuit, interrupting capacity 100kA
All	Voltage tolerance	± 10%

## Power consumption

	Mode	Imaging unit	Finishing unit
EUR/ USA	Stand-by:	approx. 3,4 BTU/hour	approx. 170 BTU/hour
	Sleep:	approx. 55 BTU/hour	-
	Operation:	approx. 240 BTU/hour	approx. 7100 BTU/hour



## Power cables

**i** The equipment is delivered with the power cables required for the installation (USA only, outside USA these must be ordered separately).

If, for some reason, you decide to use cables others than the supplied, make sure that they conform to the directions given below.

**h** If you are replacing a plug, be aware that the yellow/green conductor may only be connected to a terminal marked  $\oplus$  or  $\perp$ .

### Printer + RIP workstation (USA)

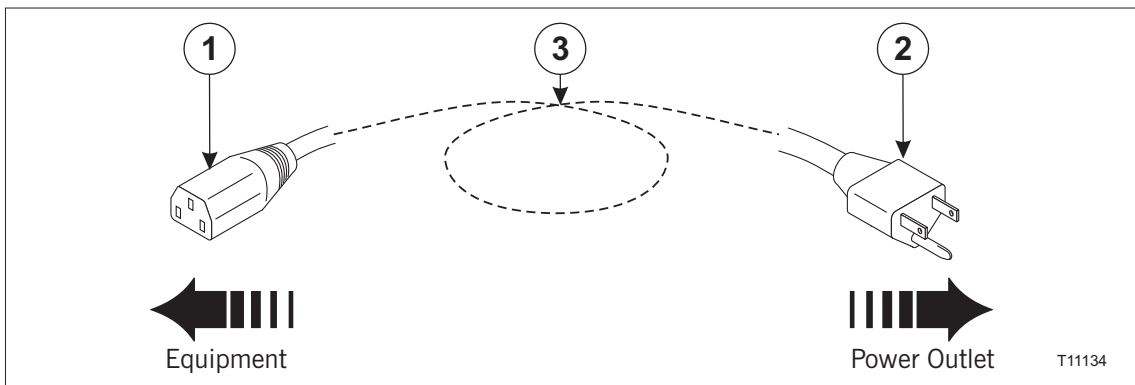

1. Appliance coupler (IEC 60320)
2. Plug type NEMA 5-15P
3. Cable min. 3 x 18 AWG, type SJT or harder service

### Printer + RIP workstation (rest of world, upon order only)

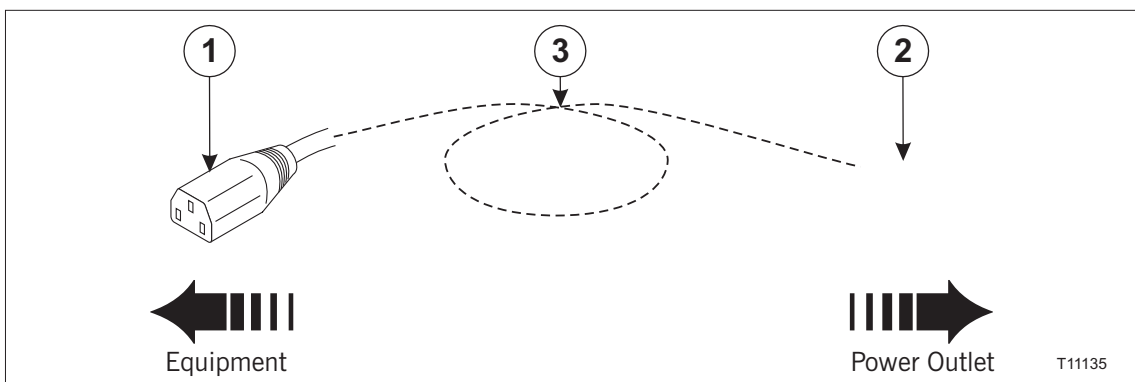

1. Appliance coupler (IEC 60320)
2. Plug type may vary
3. Cable min. 3 x 18 AWG, type SJT or harder service

## Finishing unit (USA)

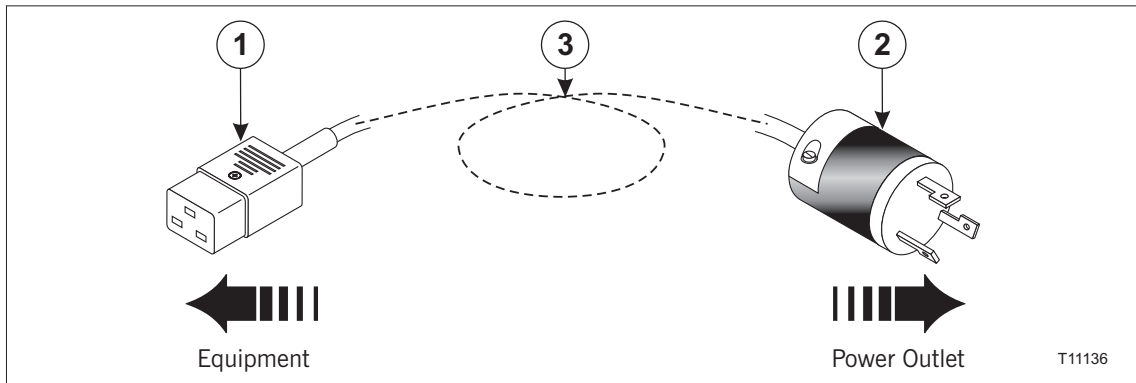

1. Appliance coupler 16A (IEC 60320)
2. Plug type NEMA L6-15P, 230V AC, 15A
3. Cable min. 3 x 18 AWG, type SJT or harder service

## Finishing unit (rest of world)

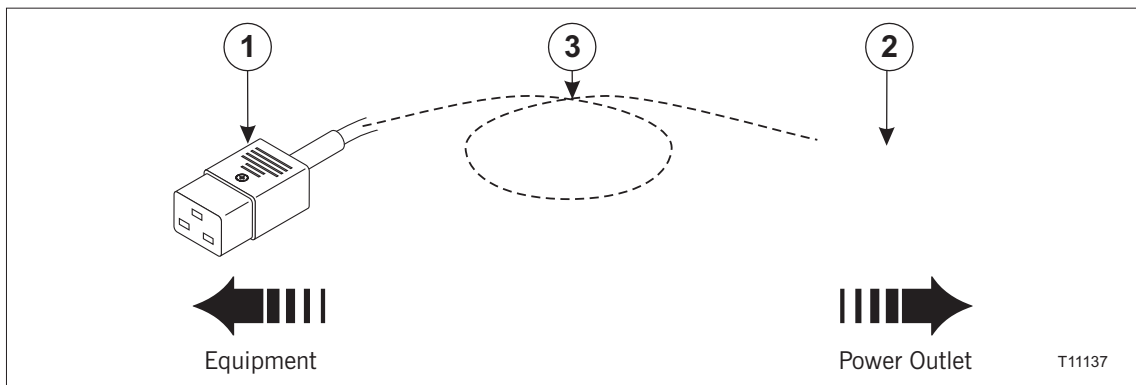

**i** A connector plug only included with the maintenance kit when the country of installation is specified upon order.

- 29759, Cable, maintenance kit, Europe
- 29760, Cable, maintenance kit, UK
- 29761, Cable, maintenance kit, Denmark
- 29762, Cable, maintenance kit, Italy
- 29763, Cable, maintenance kit, Switzerland

**i** When deciding what type of cable to use, take into account the mechanical resistance (operator may step onto cable).  
The conductors in the power supply cable should be of copper.  
Provide for additional cable protection, e.g., cable covers, if cable is exposed to heavier transport such as fork-lift trucks etc.



# Part 4: Pre-installation checklist

Please ask the customer to answer the following questions in order to ensure a trouble-free installation of the processor:

- 1. Delivery of the crate and transport to the installation site** **YES** **NO**
- A. Is there a place indoors where the crates box can be stored temporarily?
  - B. Is there a hand-powered pallet mover, a fork-lift truck or any other lifting device available?
  - C. Can the crates be transported directly to the installation site?  
*See minimum width specifications on page 2-1.*
  - D. Are there other factors (stairs, elevators, obstacles, etc.) which should be taken into account when transporting the crate or processor?    
If so, explain: .....  
.....  
.....  
.....  
.....
  - E. Are there any known problems in the building where the PlateWriter will be installed?    
If so, explain: .....  
.....  
.....  
.....  
.....  
.....  
.....  
.....  
.....  
.....

**2. Power supply & network**

- A. Make a note of the present supply specifications:  
 No. of phases ..... Voltage ..... V Fused by ..... Amps  
 Neutral wire? ..... Earth wire? ..... Frequency ..... Hz **YES** **NO**
- B. Is there a house electrician available?
- C. Is there a network connection nearby?

- |  | YES                      | NO                       |
|--|--------------------------|--------------------------|
| <b>3. Ventilation and ink storage</b>  |                          |                          |
| A. Is air condition/ventilation system capable of maintaining room temperature between 20 and 24°C (68 and 75°F) and relative humidity between 40 and 80%? | <input type="checkbox"/> | <input type="checkbox"/> |
| B. Is capacity of air condition/ventilation adequate with regard to BTU as specified on page 3-6?  | <input type="checkbox"/> | <input type="checkbox"/> |
| C. Is there a proper storage facility for ink cartridges?  | <input type="checkbox"/> | <input type="checkbox"/> |

**4. Disposition of the various supplies and equipment on the installation site:**

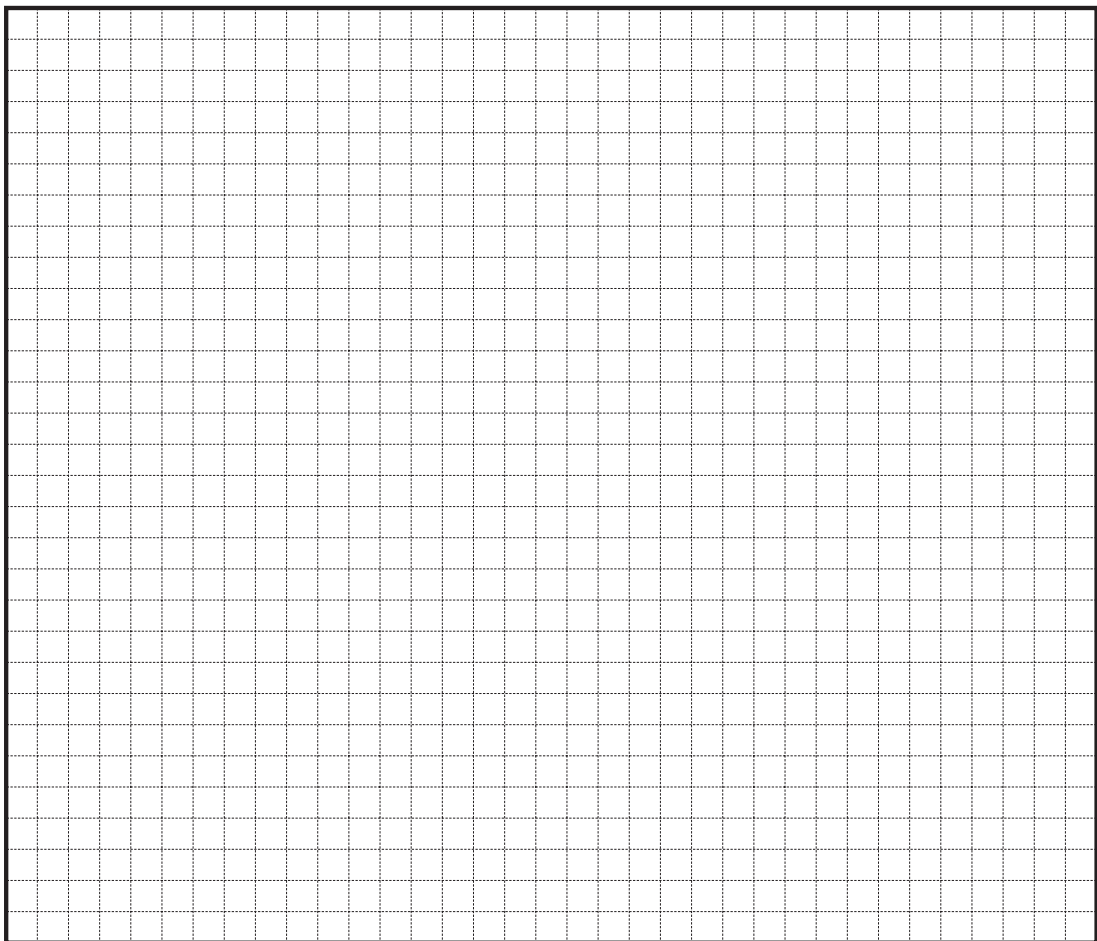

T31695