



Pre-installation Guide

Flex-Pose 360/420

► **IMPORTANT**

Please follow the instructions in this guide when preparing the installation site prior to arrival and installation of the equipment.

GLUNZ & JENSEN 

September 18th, 2024
Edition CB, Part No 10090790
English (en-us) Original version

(Blank)

About this manual

This manual applies to the combined unit **Flex-Pose 360/420**.

This manual is published by:

Glunz & Jensen A/S

Selandia Park 1

DK-4100 Ringsted

Denmark

Phone: +45 57 68 81 81

E-mail: gj@glunz-jensen.com

Internet: www.glunz-jensen.com

Copyright © September, 2024 by Glunz & Jensen A/S

Table of Contents

About this manual	3
Table of Contents	4
Introduction	5
Reservations	5
Introduction	5
Notes, Cautions and Warnings!	5
Transportation	7
When the equipment arrives	7
Storing of the equipment prior to the installation	7
The crate	7
Crate Dimensions	7
Weight	8
Checking the crate for damage	8
Handling the crate	8
Lifting the crate	9
Required width of passage and doorways	9
Installation requirements	11
Heating and ventilation	11
Installation kit	11
Space requirements	12
Free space around the equipment	12
Dimensions	13
Connections	14
Exhaust connection	15
Compressed air	15
Electrical requirements	16
Main power outlet	16
Power cable	16
Electrical specifications	17
Power supply requirements	17
Power consumption	17
Checklist	19

Introduction

Reservations



- This manual was written and illustrated using the best possible information available at the time of publication.
- Any differences between this manual and the equipment reflect improvements introduced after the publication of the manual.
- Changes, technical inaccuracies and typographic errors will be corrected in subsequent editions.
- As a part of our policy of continuous improvement, we reserve the right to alter design and specifications without further notice.

Introduction

The instructions in this Pre-installation Guide help the customer and the Service Technician to prepare the installation site for the arrival and installation of the equipment.

Notes, Cautions and Warnings!

Notes, cautions, and warnings in this manual are used and categorized as described below:

Symbol	Meaning	Explanation
	NOTE	The operator should observe and/or act according to the information in order to obtain the best possible function of the equipment.
	CAUTION	The operator must observe and/or act according to the information in order to avoid any mechanical or electrical damage to the equipment.
	WARNING	The operator must observe and/or act according to the information in order to avoid any personal injury.



(blank page)

Transportation

When the equipment arrives

Storing of the equipment prior to the installation

The equipment will usually be delivered some time before the arrival of the service technician. Provide for an appropriate place indoor to store the crated equipment until the service technician arrives.

The crate

Crate Dimensions

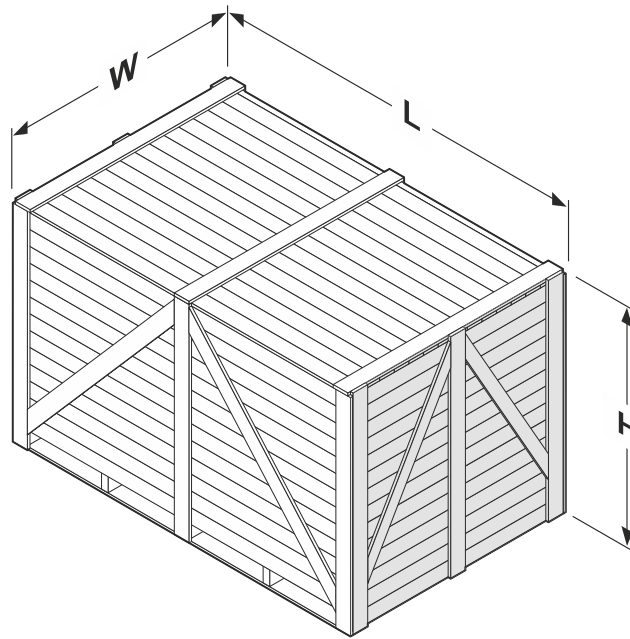

	Flex-Pose 360	Flex-Pose 420
Length (L)	2000 mm (78.7")	2330 mm (91.7")
Width (W)	2050 mm (80.1")	2450 mm (96.5")
Height (H)	1550 mm (61.0")	1520 mm (59.8")

Weight

	Flex-Pose 360	Flex-Pose 420
With crate	1100 kg (2430 lbs)	1400 kg (3087 lbs)
Without crate	800 kg (1760 lbs)	1050 kg (2315 lbs)

Checking the crate for damage

Upon receipt of the machinery, check if the crate is damaged on delivery at the customer's address. Make notes of any damages, before opening the crate. Provide a detailed description and take a photograph of the damage.

Report any damage of the crate to the shipping company and notify the insurance agent, if appropriate, before the mishandled package is open.

Check the Tilt watch and the Shock watch label that the red mark has not appeared and compare their serial numbers with those on the box label whether they match.

Handling the crate

The icons on the crate indicate how to handle the crate during transport and storage:



Ensure that the side indicated by the arrows is always up.



Handle the crate with care



Never expose the crate to water, or place it in a high-humidity area.



Do not stack the crates.



Do not tilt the crate.

Lifting the crate

The equipment is supplied in a wooden crate on a pallet.

A forklift truck is required for lifting the crate on arrival and for lifting the equipment off the pallet.



WARNING: The equipment is very heavy equipment. It is only possible to lift the equipment off the pallet using a forklift truck or a pallet mover.



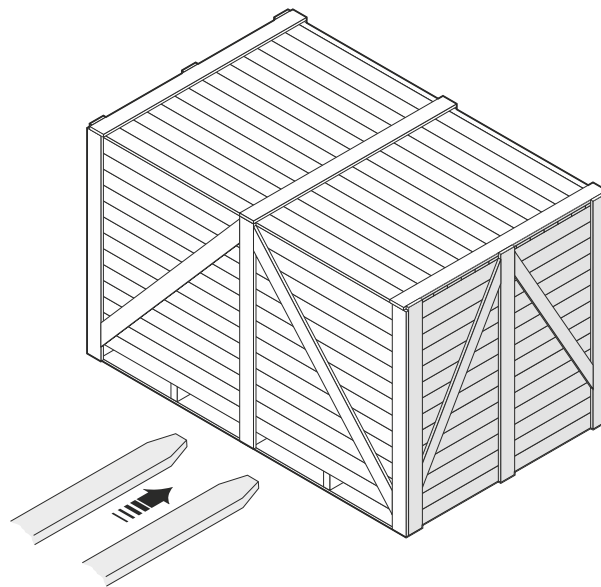

CAUTION: Make sure to provide a forklift designed and adequate for lifting a crate of the size and weight as specified in this manual.



Required width of passage and doorways

Depending on the width of the passage- and doorways through which the equipment has to be transported to the installation site, the service technician may have to perform the actions described in the table below:

If width of the doorway is ...	Flex-Pose 360	Flex-Pose 420	Then ...
More than	2100 mm (82.7")	2500 mm (98.4")	The crated equipment can be transported immediately to the installation site.  CAUTION: May require machine moving skates suitable for transport of very heavy equipment.
Less than but more than	2100 mm (82.7") 1940 mm (76.4")	2500 mm (98.4") 2400 mm (94.5")	The Service Technician has to unpack the equipment.  CAUTION: May require machine moving skates suitable for transport of very heavy equipment.



(blank page)

Installation requirements



WARNING: The equipment must be installed in restricted access locations only.



NOTE: Check the delivery route to the installation location for necessary clearance and remove all obstructions.

Heating and ventilation

Provide a heat and ventilation system capable of maintaining room temperature between 17°C (63°F) and 28°C (82°F) and a relative humidity (non condensing) of min. 20% and max. 80%.

For heat emission see "Power consumption" on page 17.

Installation kit

Installation kit is included with the equipment. It comprise the parts necessary to make the installation.

Space requirements

Free space around the equipment

Decide for a proper installation site for the equipment and make sure that the free space around the equipment makes servicing possible.

The recommended minimum free space around the equipment is specified in the next illustration.

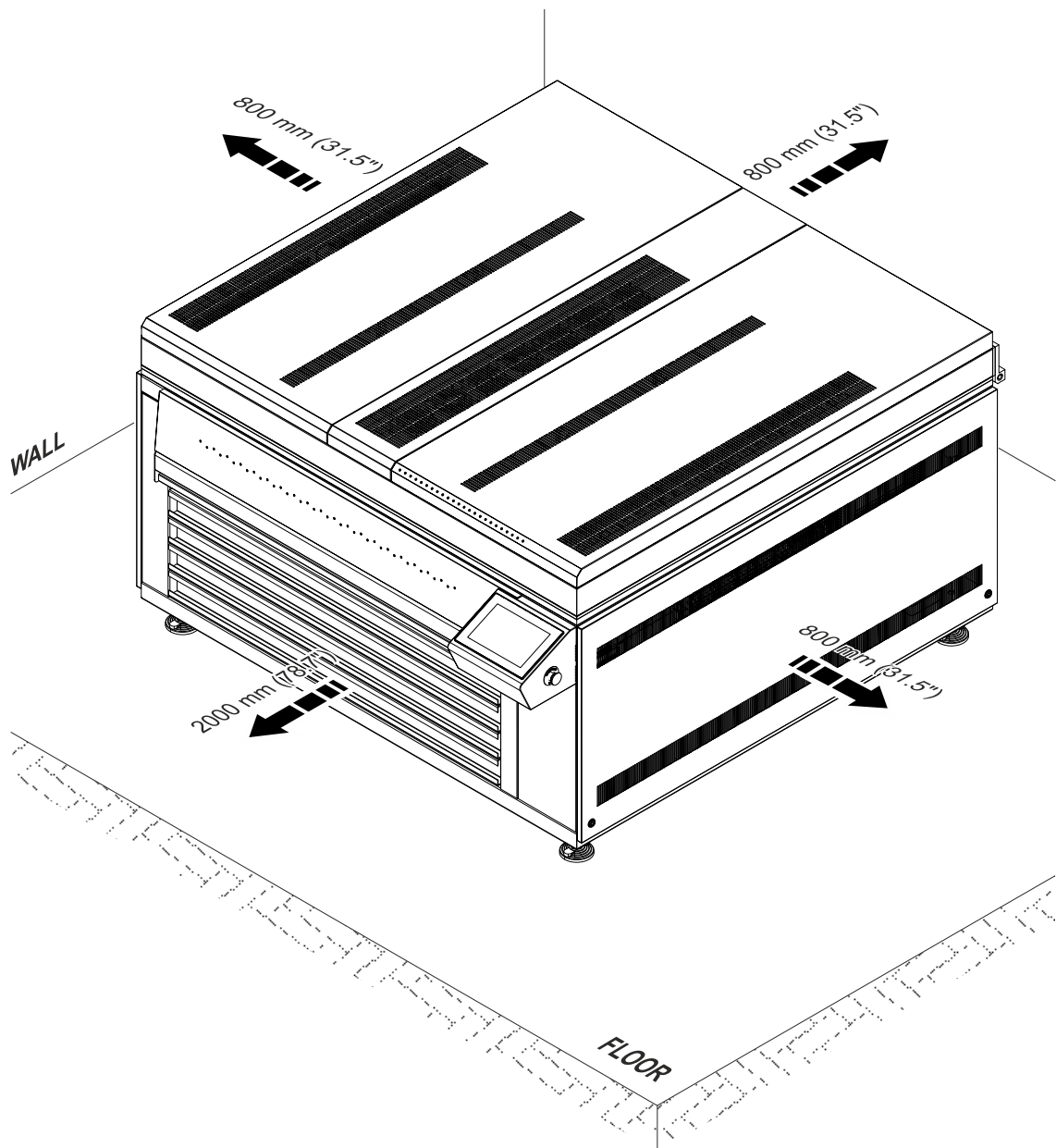

Dimensions

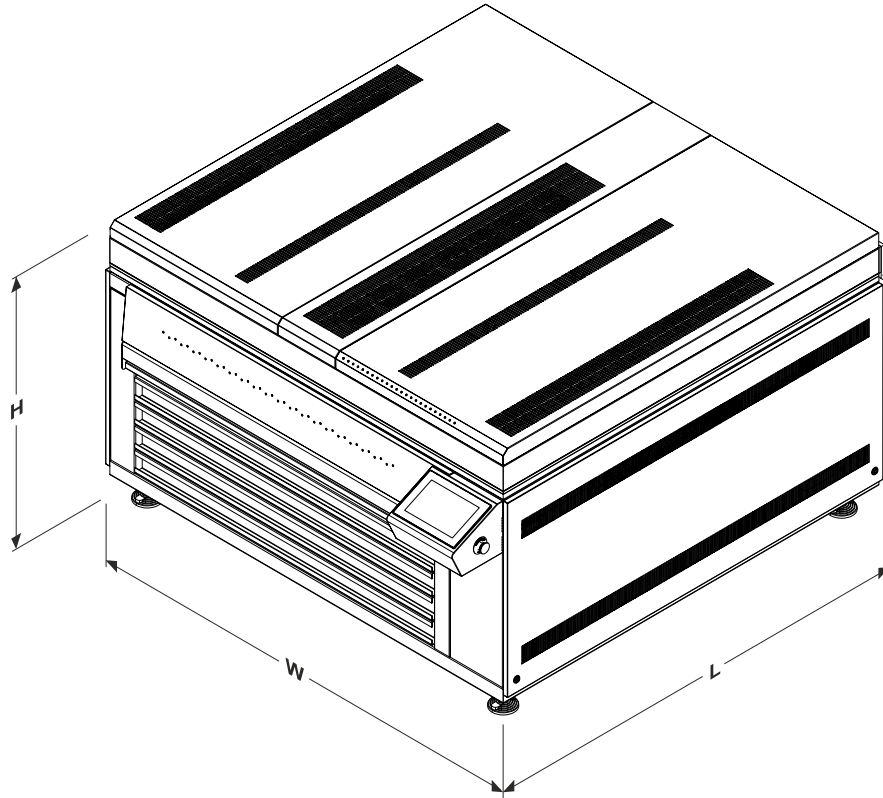

	Flex-Pose 360	Flex-Pose 420
Width (W)	1830 mm (72.1")	2150 mm (84.6")
Length (L)	1800 mm (70.9")	2100 mm (82.7")
Height (H)	1083 mm (42.6")	1100 mm (43.3")
Height (with open top lid)	2083 mm (82.0")	2300 mm (90.6")

Connections

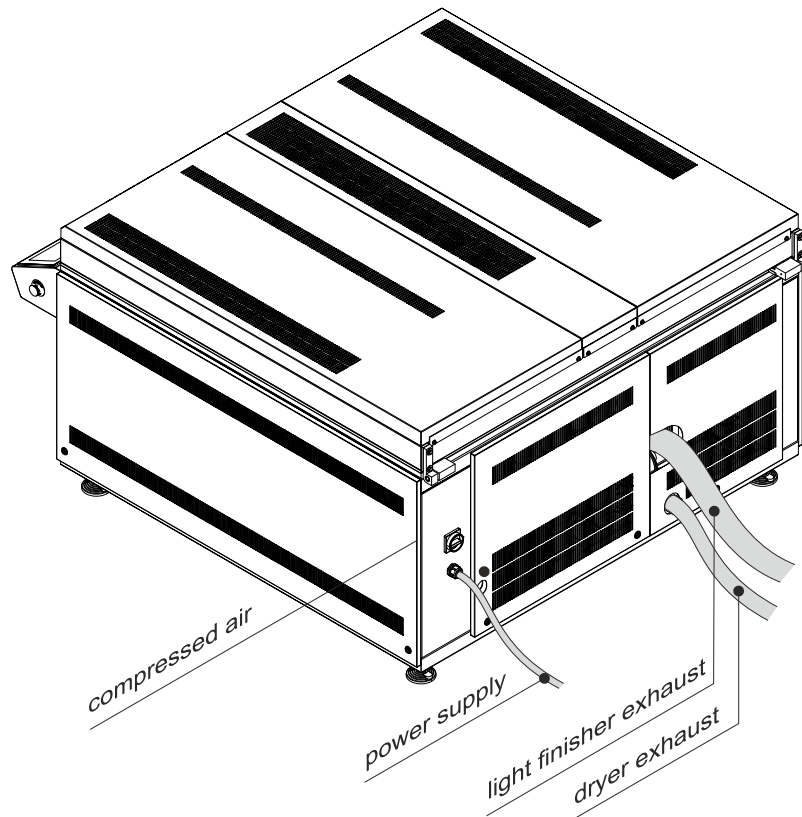

Exhaust connection

Dryer exhaust must be connected to the appropriate location (directly to the outside).

Light finisher exhaust must be connected to the appropriate and separate location (directly to the outside).



WARNING: Do not connect the dryer and light finisher exhausts together as the mixing of vapors could create explosive fumes emission depending of the solvent used to wash the plates.

Exposure exhaust does not need any connection and may blow directly to the room. Exposure exhaust can be loud and can introduce warm air into air conditioned room.



NOTE: Exposure exhaust can be loud and can introduce warm air into air conditioned room.

Make sure that the airflow is correct and minimum exhaust capacity is according to the Exhaust specification table.

	Flex-Pose 360	Flex-Pose 420
Dryer , min.	100 m ³ /h (59 ft ³ /min)	100 m ³ /h (59 ft ³ /min)
Exposure , min.	blowing directly to the room	blowing directly to the room
Light finisher , min.	800 m ³ /h (470 ft ³ /min)	800 m ³ /h (470 ft ³ /min)

Compressed air

The correct working pressure depends on the compressor as well as the design of the compressed air system, its piping, valves, filters, etc.

Different types of equipment can demand different pressures within the same system. Normally, the highest pressure determines the requisite installation pressure and other equipment will be fitted with pressure reducing valves at the point of consumption.



CAUTION: Ensure that the compressed air system is designed to give the optimal air flow without loss of pressure.

Description	Flex-Pose 360	Flex-Pose 420
Min. pressure	7 bar (100 psi)	7 bar (100 psi)
Max. pressure	10 bar (145 psi)	10 bar (145 psi)
Volume	NA	NA
Hose size	ø 6 mm	ø 6 mm

Electrical requirements



WARNING: Electrical installation, all cabling and cabling connections, fusing and isolation must conform to local and/or national regulations and guidelines.

Main power outlet

Provide an mains power-outlet with an electrical plug lockout close to the installation site. The table showing "Power supply requirements" on the facing page indicates the applicable power supply types.

Power cable



NOTE: The cable for the main power connection is not included with the equipment. Please refer to the recommended cable types described in "Power supply requirements" on the facing page.



WARNING: Connection to mains shall be permanent connection.
Connection via wall plug isn't allowed.



WARNING: The equipment is Class 1 equipment. Therefore, the equipment must be connected to earth to avoid electrical shocks.

Please be aware of double pole/neutral fusing.



CAUTION:

The conductors in the power supply cable should be of copper.

Provide for additional cable protection, e.g. cable covers, if cable is exposed to heavier transport such as fork-lift trucks etc.

Electrical specifications

Power supply requirements



CAUTION: The requirements below are specifications for preparing the installation protection. The fuses/circuit breakers must be prepared according to local regulations, and with adequate capacity as specified here. The circuit breakers must be suitable for inventor operation.



NOTE: Specifications on the equipment's name plate is the actual input current and will thus not be identical to below mentioned.

	Supply *	Fuses and cables types	
		Flex-Pose 360	Flex-Pose 420
EUR	3W + N + PE, 400 VAC, 50/60 Hz	Fused by 3 × 20 Amps Cable type: Min. 5 × 2.5 mm ² , type H07 RNF	Fused by 3 × 25 Amps Cable type: Min. 5 × 2.5 mm ² , type H07 RNF
US	3W + PE, 230 VAC, 50/60 Hz	Fused by 3 × 35 Amps Cable type: Min. 4 × 8 AWG, UL listed	Fused by 3 × 40 Amps Cable type: Min. 4 × 6 AWG, UL listed

*) Voltage tolerance ± 10%



NOTE: The power cable(s) must be in accordance with local regulations.



WARNING: Please be aware of double pole/neutral fusing.



CAUTION: The fuses must have a breaking capacity of min. 100 kA.



CAUTION: If a circuit breaker of type ELCB, RCCB, or GFCI is used where leakage to ground is detected, the trip sensitivity must be 300 mA.

Power consumption

	Flex-Pose 360	Flex-Pose 420
In operate, per phase (±10%), max.	11000 W (37600 BTU)	12000 W (41000 BTU)



(blank page)

Checklist

Please check the following conditions in order to ensure a trouble-free installation of the equipment:

- | 1. | Delivery of the crate and transport to the installation site | YES | NO |
|----|---|------------|-----------|
| A. | Is there a place indoor where the crated equipment can be stored temporarily? | o | o |
| B. | Is there a hand-powered pallet mover, a fork-lift truck or any other lifting device available? Please refer to "Lifting the crate" on page 9. | o | o |
| C. | Can the crate be transported directly to the installation site? See "Required width of passage and doorways" on page 9. | o | o |
| D. | Is it necessary to unpack the equipment before it is transported to the installation site? See "Required width of passage and doorways" on page 9. | o | o |
| E. | Are there other factors (stairs, elevators, corners, obstacles, etc.) which should be taken into account when transporting the equipment?
If YES, please describe: | o | o |
-

- | 2. | Power supply | YES | NO |
|----|---|------------|-----------|
| A. | Make a note of the present supply specifications:
Number of phases: _____ Neutral wire? o
Voltage (V): _____ Earth wire? o
Fused by (Amps): _____
Frequency (Hz): _____ | | |
| B. | Has a connection box been provided to connect the equipment to the mains? | o | o |
| C. | Has the customer been asked to provide for all supplies (cables, fuses, etc.) necessary to connect the equipment to the mains? | o | o |
| D. | Is there a house electrician available? | o | o |
| E. | Are there any known problems in the building where the equipment will be installed?
If YES, please describe which: | o | o |
-

- | 3. | Connections | YES | NO |
|----|--|-----------------------|-----------------------|
| A. | Is air condition/ventilation available according to the requirements as described in chapter "Exhaust connection" on page 15.? | <input type="radio"/> | <input type="radio"/> |
| B. | Is compressed air available according to the requirements as described in chapter "Compressed air" on page 15.? | <input type="radio"/> | <input type="radio"/> |
-

- | 4. | Web registration | YES | NO |
|----|---|-----------------------|-----------------------|
| A. | The login and password is necessary to download an available manuals for the equipment. | | |
| | <ul style="list-style-type: none"> - Click on Login and then Create new account. - Fill up the required fields and checkboxes. - Then click on CREATE NEW ACCOUNT. - After while the login information will be delivered to the specified e-mail. | <input type="radio"/> | <input type="radio"/> |
-