

Pre-installation Guide

PolyWash III D

▶ **IMPORTANT**

Please follow the instructions in this guide when preparing the installation site prior to arrival and installation of the equipment.

(Blank)

About this manual

This manual applies to the Letterpress Processor **PolyWash III D**.

This manual is published by:

Glunz & Jensen A/S

Lindholm Havnevej 29

5800 Nyborg

Denmark

Phone: +45 57 68 81 81

E-mail: gjhq@glunz-jensen.com

Internet: www.glunz-jensen.com

Copyright © December, 2018 by Glunz & Jensen A/S

Table of Contents

About this manual	3
Table of Contents	4
Introduction	5
Reservations	5
Introduction	5
Notes, Cautions and Warnings!	5
Transportation	7
When the equipment arrives	7
Storing of the equipment prior to the installation	7
The crate	7
Crate Dimensions	7
PolyWash	7
Weight	8
Checking the crate for damage	8
Handling the crate	8
Lifting the crate	9
Required width of passage and doorways	9
Installation requirements	11
Heating and ventilation	11
Installation kit	11
Space requirements	11
Free space around the equipment	11
Dimensions and connections	12
Compressed air	13
Solvent connection	13
Exhaust connection	13
Electrical requirements	14
Main power outlet	14
Power cable	14
Electrical specifications	15
Power supply requirements	15
Power consumption	15
PolyWash	15
Checklist	17

Introduction

Reservations



- This manual was written and illustrated using the best possible information available at the time of publication.
- Any differences between this manual and the equipment reflect improvements introduced after the publication of the manual.
- Changes, technical inaccuracies and typographic errors will be corrected in subsequent editions.
- As a part of our policy of continuous improvement, we reserve the right to alter design and specifications without further notice.

Introduction

The instructions in this Pre-installation Guide help the customer and the Service Technician to prepare the installation site for the arrival and installation of the equipment.

Notes, Cautions and Warnings!

Notes, cautions, and warnings in this manual are used and categorized as described below:

Symbol	Meaning	Explanation
	NOTE	The operator should observe and/or act according to the information in order to obtain the best possible function of the equipment.
	CAUTION	The operator must observe and/or act according to the information in order to avoid any mechanical or electrical damage to the equipment.
	WARNING	The operator must observe and/or act according to the information in order to avoid any personal injury.



(blank page)

Transportation

When the equipment arrives

Storing of the equipment prior to the installation

The equipment will usually be delivered some time before the arrival of the service technician. Provide for an appropriate place indoor to store the crated equipment until the service technician arrives.

The crate

Crate Dimensions

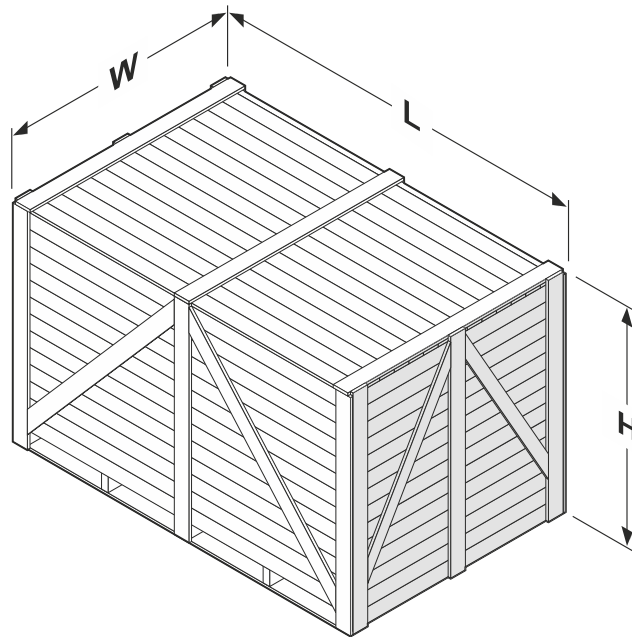

PolyWash

	PolyWash III D
Length (L)	2960 mm (116.5")
Width (W)	1880 mm (74.0")
Height (H)	1400 mm (55.1")

Weight

	PolyWash III D
With crate	1620 kg (3570 lbs)
Without crate	1320 kg (2910 lbs)

Checking the crate for damage

Check if the crate is damaged on delivery at the customer's address. Make notes of any damages, before opening the crate. Provide a detailed description and take a photograph of the damage.

Report any damage of the crate to the shipping company and notify the insurance agent, if appropriate, before the mishandled package is opened.

Handling the crate

The icons on the crate indicate how to handle the crate during transport and storage:



Ensure that the side indicated by the arrows is always up.



Handle the crate with care



Never expose the crate to water, or place it in a high-humidity area.



Do not stack the crates.





Do not tilt the crate.

Lifting the crate

The equipment is supplied in a wooden crate on a pallet.

A fork-lift truck is required for lifting the crate on arrival and for lifting the equipment off the pallet.

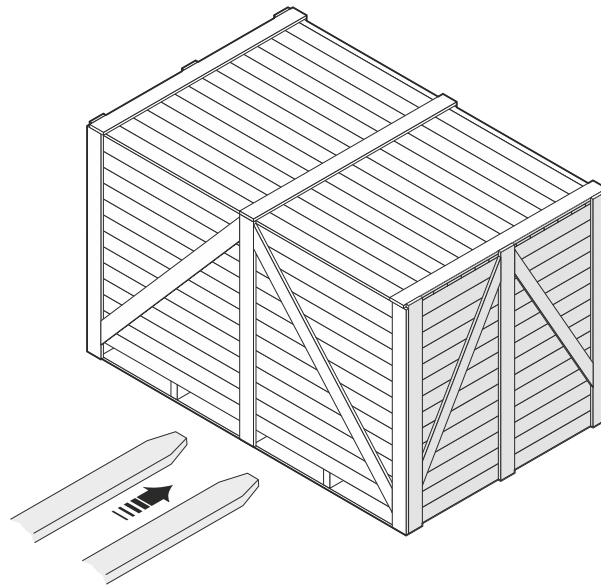

 **WARNING:** The equipment is very heavy equipment. It is only possible to lift the equipment off the pallet using a forklift truck or a pallet mover.

 **CAUTION:** Make sure to provide a forklift designed and adequate for lifting a crate of the size and weight as specified in this manual.



Required width of passage and doorways

Depending on the width of the passage- and doorways through which the equipment has to be transported to the installation site, the service technician may have to perform the actions described in the table below:

If width of the doorway is ...	PolyWash III D	Then ...
More than	1980 mm (78.0")	The crated equipment can be transported immediately to the installation site.  CAUTION: May require machine moving skates suitable for transport of very heavy equipment. Please refer to "Weight" on the previous page.
Less than but more than	1980 mm (78.0") 1780 mm (70.1")	The Service Technician has to unpack the equipment.  CAUTION: May require machine moving skates suitable for transport of very heavy equipment. Please refer to "Weight" on the previous page.



(blank page)

Installation requirements



WARNING: The equipment must be installed in restricted access locations only.



NOTE: Check the delivery route to the installation location for necessary clearance and remove all obstructions.

Heating and ventilation

Provide a heat and ventilation system capable of maintaining room temperature between 20°C (68°F) and 24°C (75°F) ±1° and a relative humidity (non condensing) of min. 50 % and max. 60 ±5%.

For heat emission see "Power consumption" on page 15.

Installation kit

Installation kit is included with the equipment. It comprise the parts necessary to make the installation.

Space requirements

Free space around the equipment

Decide for a proper installation site for the equipment and make sure that the free space around the equipment makes servicing possible.

The recommended minimum free space around the equipment is specified in the next illustration.

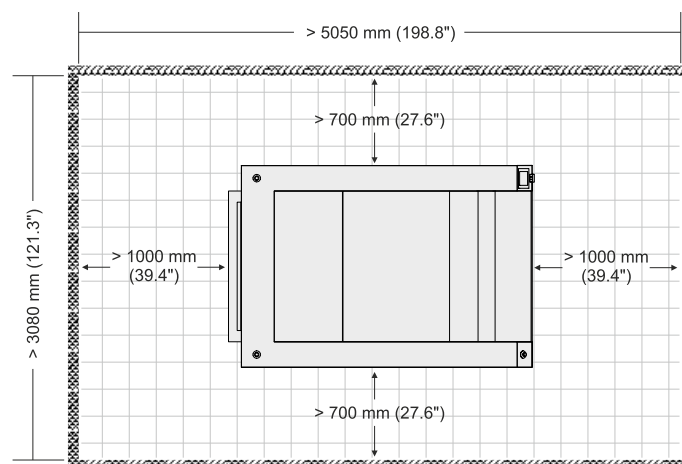

Dimensions and connections

Side view

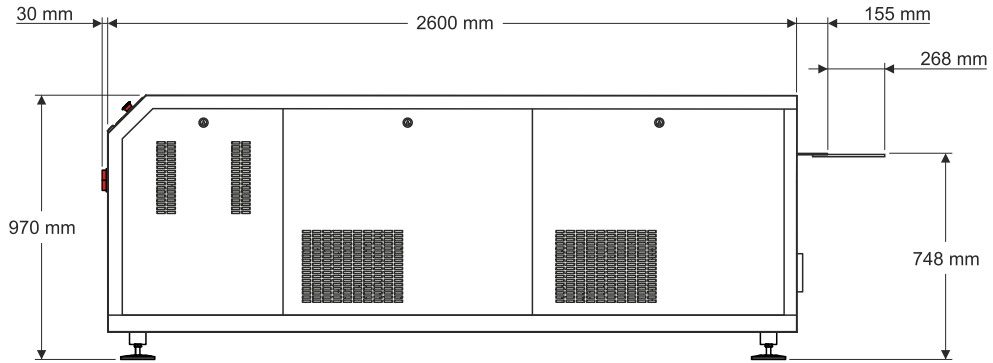

Rear view

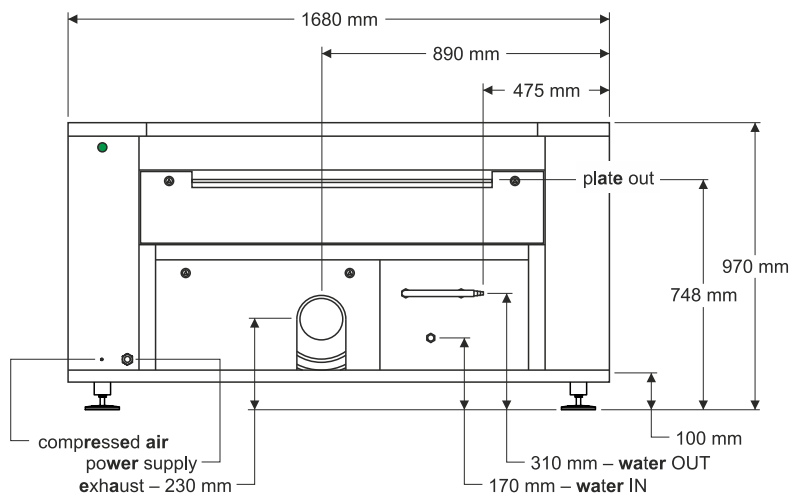

Compressed air

Description	PolyWash III D
Min. pressure	6 bar (87 psi)
Max. pressure	10 bar (145 psi)
Volume	NA
Hose size	ø 6 mm

Solvent connection

Provide a solvent connection for a ø 20 mm diameter hose, which is located no more than 5 meters from machine connections.

If the solvent barrels are more than 5 meters from the processor and the piping is lifted higher than the solvent tanks, it is recommended to mount a non-return valve at the barrels to prevent backlash of solvent or air in the hoses during process.

In case of need to turn off the solvent supply to the processor, it is recommended to install hand valves in the end of the solvent installation.



CAUTION: Never lead solvent out hose into a drain, as most solvents are strong pollutants. It is also illegal to empty these types of chemicals into the public sewer system.

Under all circumstances local regulations applying to the treatment of chemical waste must be followed strictly.

Exhaust connection

Processor exhaust must be connected to the appropriate location (directly to the outside or to the building exhaust installation).

Make sure that the airflow is correct and minimum exhaust capacity is according to the Exhaust specification table.

	PolyWash III D
Processor, min.	600 m ³ /h (353 ft ³ /min)

Electrical requirements



WARNING: Electrical installation must conform to local regulations and guidelines.

Main power outlet

Provide an mains power-outlet with an electrical plug lockout close to the installation site. The table showing "Power supply requirements" on the facing page indicates the applicable power supply types.

Power cable



NOTE: The cable for the main power connection is included with the equipment.



WARNING: The equipment is Class 1 equipment. Therefore, the equipment must be connected to earth to avoid electrical shocks.

Please be aware of double pole/neutral fusing.



CAUTION:

The conductors in the power supply cable should be of copper.

Provide for additional cable protection, e.g. cable covers, if cable is exposed to heavier transport such as fork-lift trucks etc.

Electrical specifications

Power supply requirements



CAUTION: The requirements below are specifications for preparing the installation protection. The fuses/circuit breakers must be prepared according to local regulations, and with adequate capacity as specified here. The circuit breakers must be suitable for inventor operation.



NOTE: Specifications on the equipment's name plate is the actual input current and will thus not be identical to below mentioned.

	Supply *	Fuses and cables types PolyWash III D
EUR	3W + N + PE, 400 VAC, 50/60 Hz	Fused by 3 × 13 Amps Cable type: Min. 5 × 2.5 mm ² , type H07 RNF
US	3W + PE, 230 VAC, 50/60 Hz	Fused by 3 × 24 Amps Cable type: Min. 4 × 8 AWG, type SJO

*) Voltage tolerance ± 10%



NOTE: The power cable(s) must be in accordance with local regulations.



WARNING: Please be aware of double pole/neutral fusing.



CAUTION: The fuses must have a breaking capacity of min. 100 kA.

Power consumption

PolyWash

	PolyWash III D
In operate, per phase (±10%), max.	8500 W (29000 BTU)



(blank page)

Checklist

Please check the following conditions in order to ensure a trouble-free installation of the equipment:

- | | | | |
|-----------|--|------------|-----------|
| 1. | Delivery of the crate and transport to the installation site | YES | NO |
| A. | Is there a place indoor where the crated equipment can be stored temporarily? | o | o |
| B. | Is there a hand-powered pallet mover, a fork-lift truck or any other lifting device available? Please refer to "Lifting the crate" on page 1 for required lifting equipment. | o | o |
| C. | Can the crate be transported directly to the installation site? See "Required width of passage and doorways" on page 9.. | o | o |
| D. | Is it necessary to unpack the equipment before it is transported to the installation site? See "Required width of passage and doorways" on page 9.. | o | o |
| E. | Are there other factors (stairs, elevators, corners, obstacles, etc.) which should be taken into account when transporting the equipment?
If YES, please describe: | o | o |
-

- | | | | |
|-----------|---|------------|-----------|
| 2. | Power supply | YES | NO |
| A. | Make a note of the present supply specifications:

Number of phases: _____ Neutral wire? o
Voltage (V): _____ Earth wire? o
Fused by (Amps): _____
Frequency (Hz): _____ | | |
| B. | Has a connection box been provided to connect the equipment to the mains? | o | o |
| C. | Has the customer been asked to provide for all supplies (cables, fuses, etc.) necessary to connect the equipment to the mains? | o | o |
| D. | Is there a house electrician available? | o | o |
| E. | Are there any known problems in the building where the equipment will be installed?
If YES, please describe which: | o | o |
-

- | | | | |
|-----------|--|------------|-----------|
| 3. | Connections | YES | NO |
| A. | Is air condition/ventilation available according to the requirements as described in chapter "Exhaust connection" on page 13.? | o | o |
| B. | Is compressed air available according to the requirements as described in chapter "Compressed air" on page 13.? | o | o |

- | | | | |
|----|--|--------------------------|--------------------------|
| C. | Is solvent connection available according to the requirements as described in chapter "Solvent connection" on page 13. | <input type="checkbox"/> | <input type="checkbox"/> |
| D. | Availability of warm water for cleaning of the equipment? | <input type="checkbox"/> | <input type="checkbox"/> |
| E. | Is the tap water temperature adjustable? | <input type="checkbox"/> | <input type="checkbox"/> |
| F. | Is the supply water pressure min. 6 bar (87 psi)? | <input type="checkbox"/> | <input type="checkbox"/> |