

User's Manual

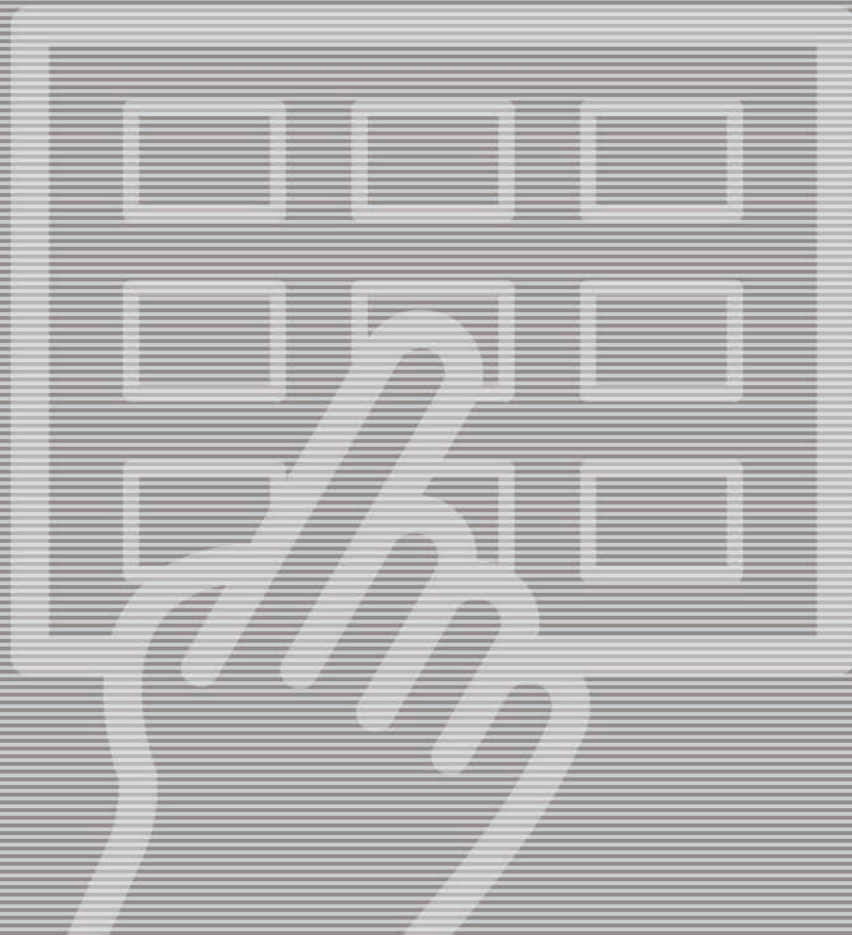

MPT Control Panel

MPT Control Panel

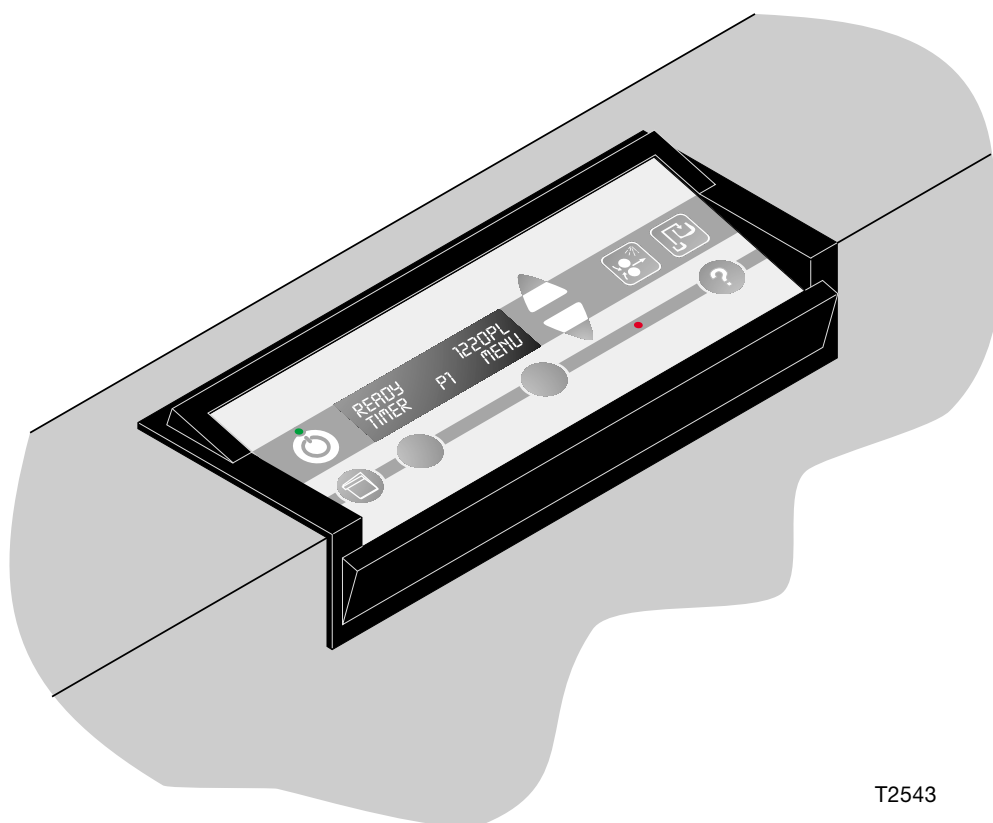

T2543

This manual is for daily users of the equipment. Always read the *Safety Instruction Manual part No 21741* before starting up the equipment and keep manuals with the machine for reference at all times.

MPT CONTROL PANEL

GENERAL INFORMATION

Copyright © 2005 by Glunz & Jensen A/S.

This manual is valid for plate processors 68 and 85 Thermal and Polymer.

The manual was written and illustrated using the best possible information available at the time of publication.

Any differences between the manual and the equipment reflect improvements introduced after the publication of the manual.

Changes, technical inaccuracies, and typographic errors will be corrected in subsequent editions.

As a part of our policy of continuous improvement, we reserve the right to alter design and specifications without further notice.

1.06.00/1.06.00 HD

WARNINGS, CAUTIONS AND NOTES!

Throughout the manual warnings, cautions, and notes are written in italics on a grey background like the example below:

NOTE! The various functions briefly mentioned below are described more detailed later in this manual.

Explanation:

NOTE!

The operator should observe and/or act according to the information in order to obtain the best possible function of the equipment.

CAUTION!

The operator must observe and/or act according to the information in order to avoid any mechanical or electrical damage to the equipment.

WARNING!

The operator must observe/and or act according to the information in order to avoid any personnel injury.

MPT CONTROL PANEL

TABLE OF CONTENTS

	PAGE
GENERAL INFORMATION	0.2
WARNINGS, CAUTIONS AND NOTES!	0.3
1. THE CONTROL PANEL	1.1
INTRODUCTION	1.1
SYMBOLS	1.3
KEYS AND INDICATORS	1.5
POWER ON INDICATOR	1.5
STAND-BY KEY	1.5
UP/DOWN KEYS	1.5
DISPLAY	1.5
SELECTION KEYS	1.5
QUICK-SET KEY	1.5
ALARM LAMP	1.7
MANUAL START KEY)	1.7
MANUAL REPLENISH KEY	1.7
HELP-TEXT KEY	1.9
GENERAL CONTROL PANEL FUNCTIONS	1.11
OPERATING MODES	1.11
OFF MODE	1.11
STAND-BY mode	1.11
PROCESS mode	1.11
TURNING MAIN POWER ON	1.13
TURNING MAIN POWER OFF	1.13
INITIALIZATION FAIL	1.15
"FAIL NOT FOUND"	1.15
START-UP	1.17
SWITCHING ON USING THE STAND-BY KEY	1.17
SWITCHING ON USING THE TIMER FUNCTION	1.17
SHUT-DOWN	1.19
SWITCHING OFF WITHOUT USING THE MANUAL TIMER FUNCTION	1.19
SWITCHING OFF WITH MANUAL TIMER FUNCTION	1.19
PROCESSING	1.21
DETAILED MENU DESCRIPTIONS	1.23
MENU STRUCTURE	1.23
PROGRAMS	1.25
SELECTING A PROGRAM, OR CHANGING PROGRAM SETTINGS	1.27
AUTO PROGRAM	1.29

TABLE OF CONTENTS

	PAGE
.....	
STATISTICS.....	1.31
FUNCTIONS.....	1.33
MANUAL REPLENISH.....	1.33
MANUAL START.....	1.33
TIMER (MANUAL).....	1.35
ALARMS.....	1.35
SETUP.....	1.37
CONTROL PANEL.....	1.37
LEFT KEY.....	1.37
DISP (DISPLAY).....	1.39
DISPLAY LIGHT.....	1.41
DISPLAY CONTRAST.....	1.41
SOUND.....	1.41
BLACK OUT.....	1.41
EDIT LOCK.....	1.41
PLATE SIZES.....	1.43
INFORMATION.....	1.43
ABSOLUTE VALUES.....	1.43
AUTO TIMER.....	1.45
CLOCK.....	1.47
MONITOR.....	1.47
SERVICE.....	1.47
2. ALARMS AND MESSAGES.....	2.1
GENERAL.....	2.1
WAIT, BUSY, ALARM ETC.....	2.1
STATUS MESSAGES.....	2.2
ALARMS/MESSAGES LIST.....	2.4
HOW TO READ THE ALARMS/MESSAGES LIST.....	2.4
ABBREVIATIONS USED IN THE ALARMS/MESSAGES LIST.....	2.4
EXPLANATION OF THE ALARM DISPLAY.....	2.16
DISPLAYING ALARMS.....	2.16
USER ACTION.....	2.17
EXIT.....	2.17
OK.....	2.17
3. CUSTOMERS NOTES.....	3.1
PARAMETER SETTINGS LISTS.....	3.1

MPT CONTROL PANEL

1. THE CONTROL PANEL

INTRODUCTION





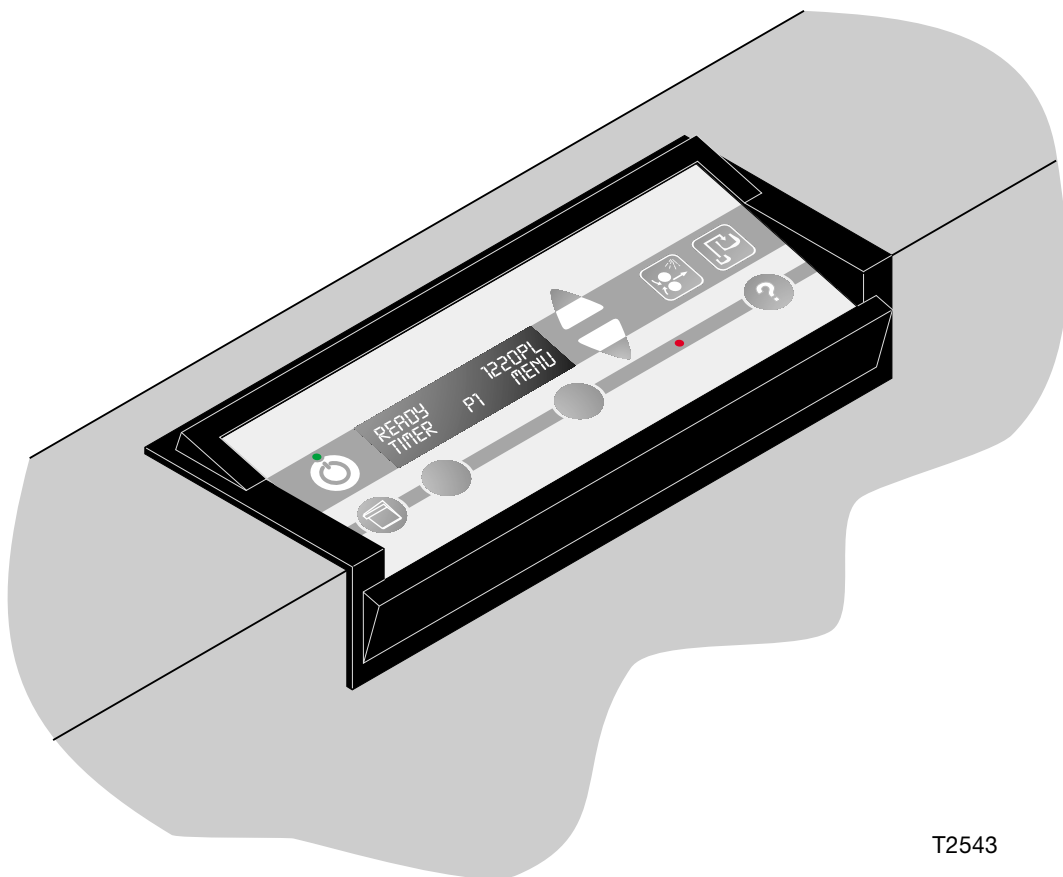





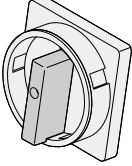

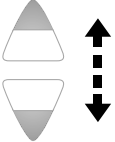

The control panel described in this manual is for Plate Processors, as specified on page 0.2, offline as well as online.

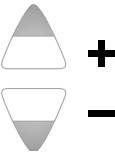
On the next pages are general description of the control panel keys and indicators followed by descriptions of operation and programming procedures and menu structure with detailed functional descriptions.

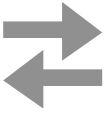

T2543

MPT CONTROL PANEL

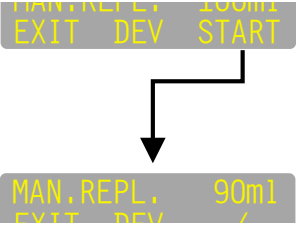
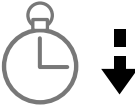
Action by operator			
	Switch processor's main switch to "I" (= on) or "O" (= off).		Press QUICK-SET key
	Press STAND-BY key		Press DEV REPLENISH key
	Use UP/DOWN keys to scroll between menu items.		Press MANUAL START key
	Use UP/DOWN keys to adjust a value on the display.		Press HELP-TEXT key
Action by Control panel			
	The display continuously changes between two different messages.	    	Indicators on control panel :
	1) The arrow shows display changes and/or function starts/-stops when related soft key is pressed, or 2) The arrow shows display changes and/or automatic function starts/-stops at time-out etc.		Power on
			Main power supply has been off !
			Status signal (lamp lit)
		Alarm signal (lamp flashing)	
	Countdown (Sometimes visual on the display)		Bib-sound (not visual)

SYMBOLS

Opposite are shown the various symbols used in illustrations throughout this manual.

The symbols are used for explanation of the various control panel functions and display messages.

The symbols shown in the upper part of the table are meant as a help to inform the operator which button to press in the situations described later in this manual.

The symbols shown in the lower part of the table inform the operator of various control panel changes and functions.

MPT CONTROL PANEL

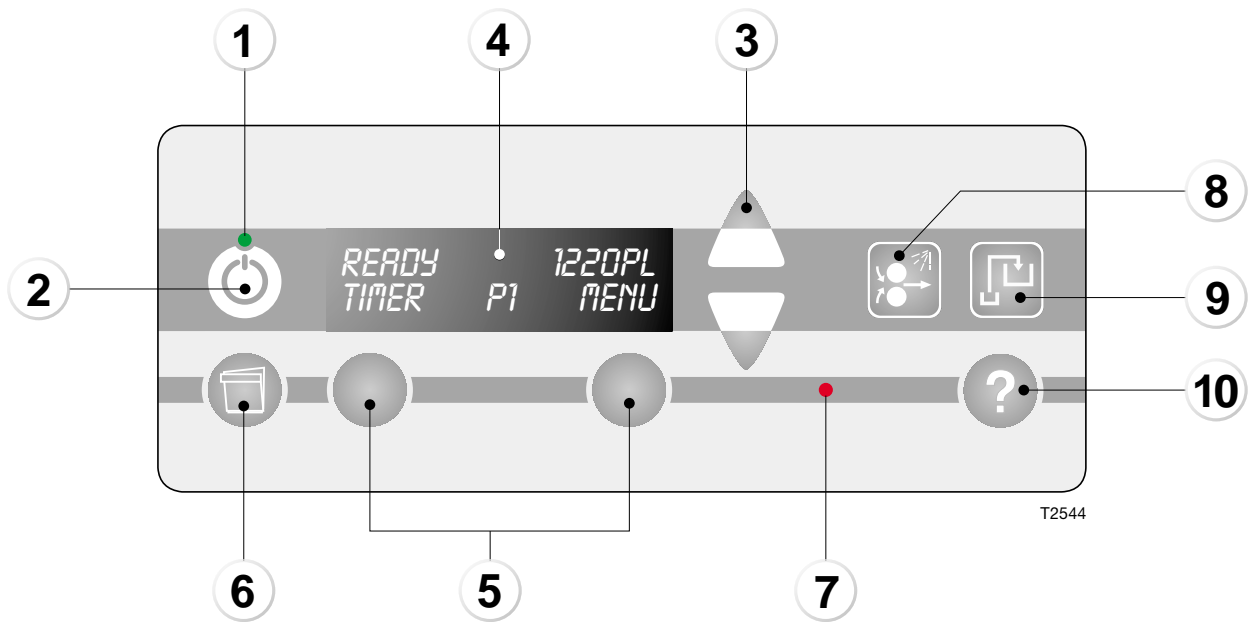

KEYS AND INDICATORS

POWER ON INDICATOR (1)

Indicates that power is on (main switch is set to "I"). When flashing it indicates that main power supply has been off for a while. When starting up the processor - pressing the stand-by key (2) - the indicator stops flashing.

STAND-BY KEY (2)

Switches the processor from off mode into stand-by mode and opposite.

See description of "OFF MODE" and "STAND-BY MODE" on page 1.11.

UP/DOWN KEYS (3)

Use the up/down keys to

- Scroll between display settings in the upper right corner. See "DISP" (display) on page 1.39.
- Scroll between menu items.
- Adjust settings of various programs/parameters.

DISPLAY (4)

The display holds 2 lines of 16 characters each:

The top line displays:

- Left:
- Processor status: Wait, ready, alarm etc. See detailed description in the table with status messages in chapter 2.
 - Alarms, messages, and help text.
 - Input/output device name* (for service technicians).
- Right:
- Values.
 - Program parameters/settings*.
 - Status of input/output device* (for service technicians).

*) Units can be set in Metric or US values. To be set by a service technician.

The bottom line displays:

- Left/right: - Functions of left and right selection keys.
- Middle: - Selected program or active processor section.

SELECTION KEYS (5)

Key functions are displayed in the bottom line of the display (4).

Use keys ex. to:

- Enter the left-key function. See "LEFT KEY" on page 1.37.
- Enter menus/parameters.
- Confirm changed values/parameters.
- Cancel adjustments/exit functions.
- Start/stop various functions.

QUICK-SET KEY (6)

Activating the quick-set key enables you to view and change settings for the active function.

The function of the key depends on the processor mode or which parameter is active.

The quick-set key can be activated in following functions:

- "READY" (stand-by mode):
Change of settings or resetting of the active display selection (DISP). See description of "DISP" (display) on page 1.39.
- FUNCTIONS:
Manual "TIMER" - change of start-up day and time. See description on page 1.35.

MPT CONTROL PANEL

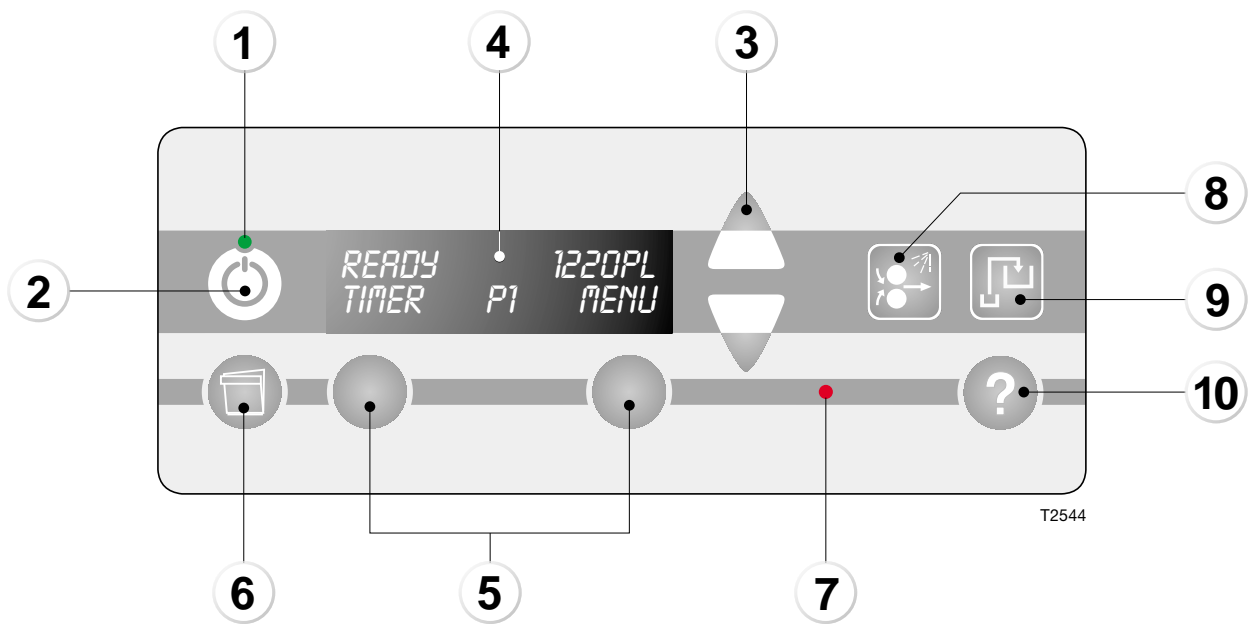

ALARM LAMP (7)

The alarm lamp will indicate occurrence of abnormal conditions/alarms. At the same time the top line of the display shows "ALARM".

Some alarms will be combined with a sound signal.

The different behaviors of the alarm lamp combined with sound are described in detail in chapter 2 "ALARMS AND MESSAGES".

MANUAL START KEY (8)

Key for manual start of process mode.

When pressing the manual start key the processor switches to process mode.

This function is for:

- rewash purpose,
- rinse process, or
- eject of jammed material.

The manual start function can be activated from the control panel menu as well.

See detailed description of the manual start function in "MANUAL START" on page 1.33.

MANUAL REPLENISH KEY (9)

Key for manual replenish:

- Press once :
 - The display shows a specified amount of replenishment to be added to the developer tank, or
 - If the processor is equipped with more than one replenish pump the display shows a list of sections in which manual replenish can be activated:
 - PREWASH REPL
 - DEV REPL
 - WASH REPLPress the up/down keys to select between the sections. Press enter for chosen section. The chosen section is displayed with a preset amount of replenishment to be added.

- Press "START" to activate the function, **or**
- Press the manual replenish key once more to add another 50 ml of replenish to the specified amount. Press "START" to add the new amount.

It is also possible to change the specified amount to be pumped with the up/down keys:

- Press the manual replenish key and the display shows a specified amount of replenishment to be added to the developer tank, or if more than one pumps is installed the display shows a list of sections in which manual replenish can be activated, in this case select a section.
- Press the up/down keys to change the amount and press "START" to activate the replenish pump.
- Pressing "EXIT" will return to stand-by display. Manual replenish function will continue until correct amount is reached.

NOTE! The manual replenish key can be activated in stand-by mode only.

MPT CONTROL PANEL

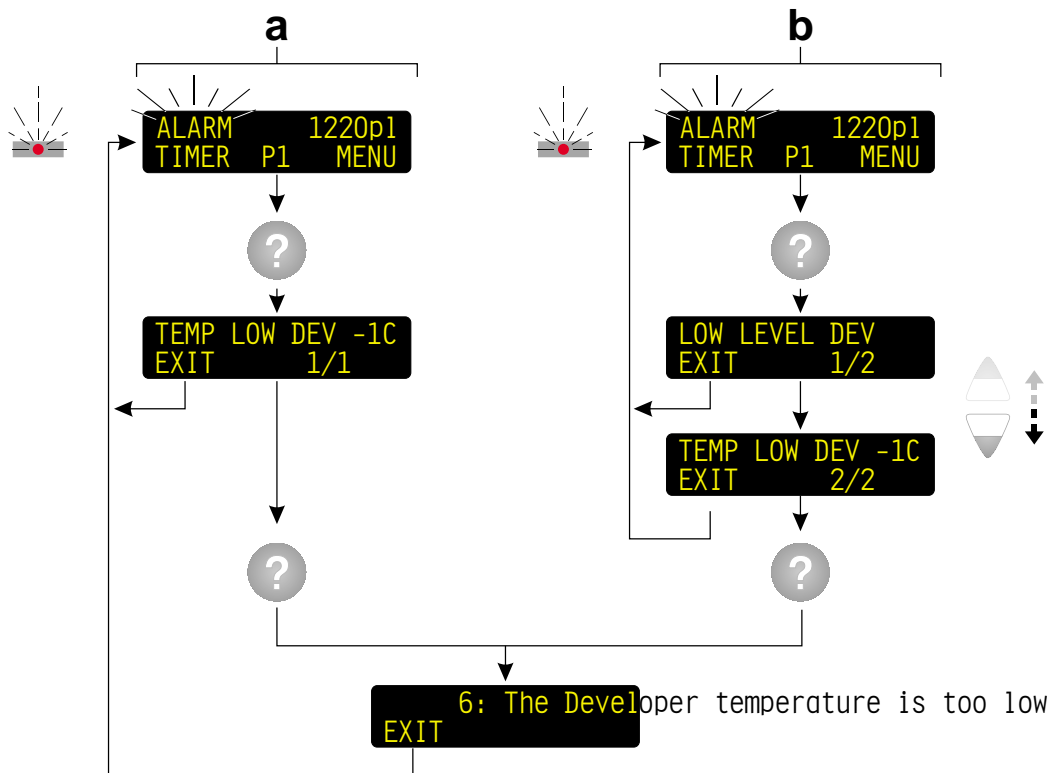
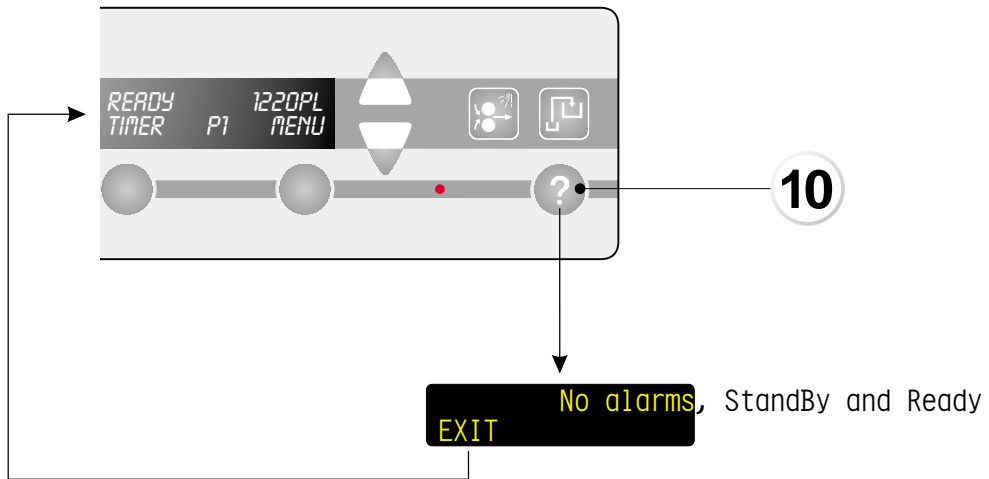

T2572

HELP-TEXT KEY (10)

NOTE! Some functions/parameters only.

The help-text key gives short explanations:

- For menus and parameters with abbreviations expected to be unknown to the operator.
- To all alarms and messages.

Pressing the help-text key while processing, programming, or scrolling through alarms or functions/parameters will display the help-text.

For more detailed information of the control panel menus, the parameters and alarm messages please refer to descriptions in this manual.

Scrolling through menus and parameters:

(See example in upper diagram opposite.)

Press once and the help-text function will shortly explain the displayed menu/function or parameter.

Alarms and messages:

(See examples in lower diagram opposite.)

a) - Single alarm/message:

When "ALARM" (or "WAIT") is displayed press the help-text key once. The help-text function will display the actual alarm in an abbreviated version, the numbers of the actual alarm messages (e.g. 1/1), and for some alarm types supplemented by the value deviating from the programmed value. Press the help-text key once more and a full text version of the actual alarm will scroll through the display. The full text version also shows a number. Use this number to find the alarm in the list of alarms and messages in chapter 2. Press "EXIT" to exit alarm messages.

b) - Multiple alarms/messages:

When "ALARM" (or "WAIT") is displayed press the help-text key once. The help-text function will display the actual alarm in an abbreviated version. If two or more alarms occur the help-text function will display e.g. "1/2" informing the operator that this alarm is one of two present. Press down key to see next alarm ("2/2") and press the help-text key once more to see the full text version of the actual alarm.

A complete list with alarm messages is also included in chapter 2.

MPT CONTROL PANEL

GENERAL CONTROL PANEL FUNCTIONS

OPERATING MODES

The processor can be in one of 3 different modes when main power is turned on:

OFF MODE

Power is on (main switch is set to "I"). The display is black, and the power on indicator is lit.

Functions in OFF mode:

- All processing functions are off.
- Time replenishment function is active (optional)*.
- Timer function may be active (optional) **. If active the display shows the day and time for next start-up.
- Jog function may be active (optional) *.

STAND-BY mode

When the processor is in stand-by mode it is ready to receive a plate, either from the feed table or imagesetter, or through the rewash slot.

The display shows:

- READY, WAIT or ALARM.
See table with status signals in chapter 2.
- E.g. number of plates processed.
See "DISP (display)" on page 1.39
- Functions of left and right selection keys.
See "LEFT KEY" on page 1.37
- Selected program.
See "PROGRAMS" on page 1.25.

Functions in STAND-BY mode:

- Temperature controls are on.
- Level controls are on.
- Time replenishment function is active (optional) *.
- Jog function is active. The jog function makes the transport rollers turn for a short while at intervals to prevent crystallization of chemicals on the rollers.
- Manual functions can be activated.

PROCESS mode

Process mode means that the processor is processing a plate, either from the feed table or imagesetter (display shows "PROC"), or through the rewash slot (display shows "MANUAL START").

Functions in PROCESS mode:

- Transport system runs with the set speed.
- Level controls are on.
- Developer temperature control is on.
- Dryer temperature control and blowers are on.
- Replenishment systems add replenishment to the various sections as set in the specific parameters.
- The rollers and various wash and gum spray pumps start delayed before the plate enters the respective sections.
- The processor automatically returns to stand-by mode shortly after the last plate exits.

*) Function must be set by an authorized service technician.

***) The function can be set by the user.
The function is described later in this manual.

MPT CONTROL PANEL

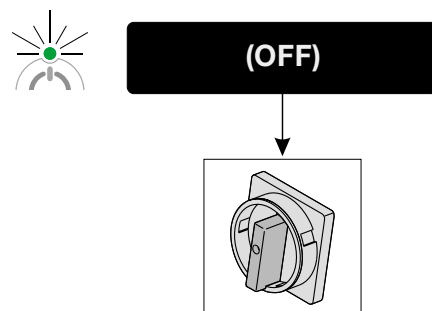
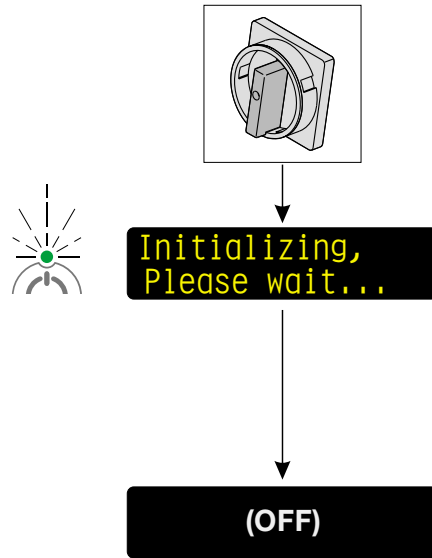

TURNING MAIN POWER ON (Turn into OFF mode)

(See upper diagram opposite.)

- Turn main switch to "I" (= on).
- The power on indicator is flashing, the processor initializes for a short while and then turns into off mode.

"OFF MODE" functions is described on page 1.11.

"START-UP" of the processor is described on page 1.17.

TURNING MAIN POWER OFF (From OFF mode)

(See lower diagram opposite.)

- Press the stand-by key to switch the processor from stand-by mode into off mode. Display will turn black.
- When the processor is in off mode turn main switch to "0" (= off).

NOTE! Power supply should only be turned off for holidays or for maintenance and servicing purposes. Normally the processor should be switched into off mode only.

"OFF MODE" functions is described on page 1.11.

MPT CONTROL PANEL

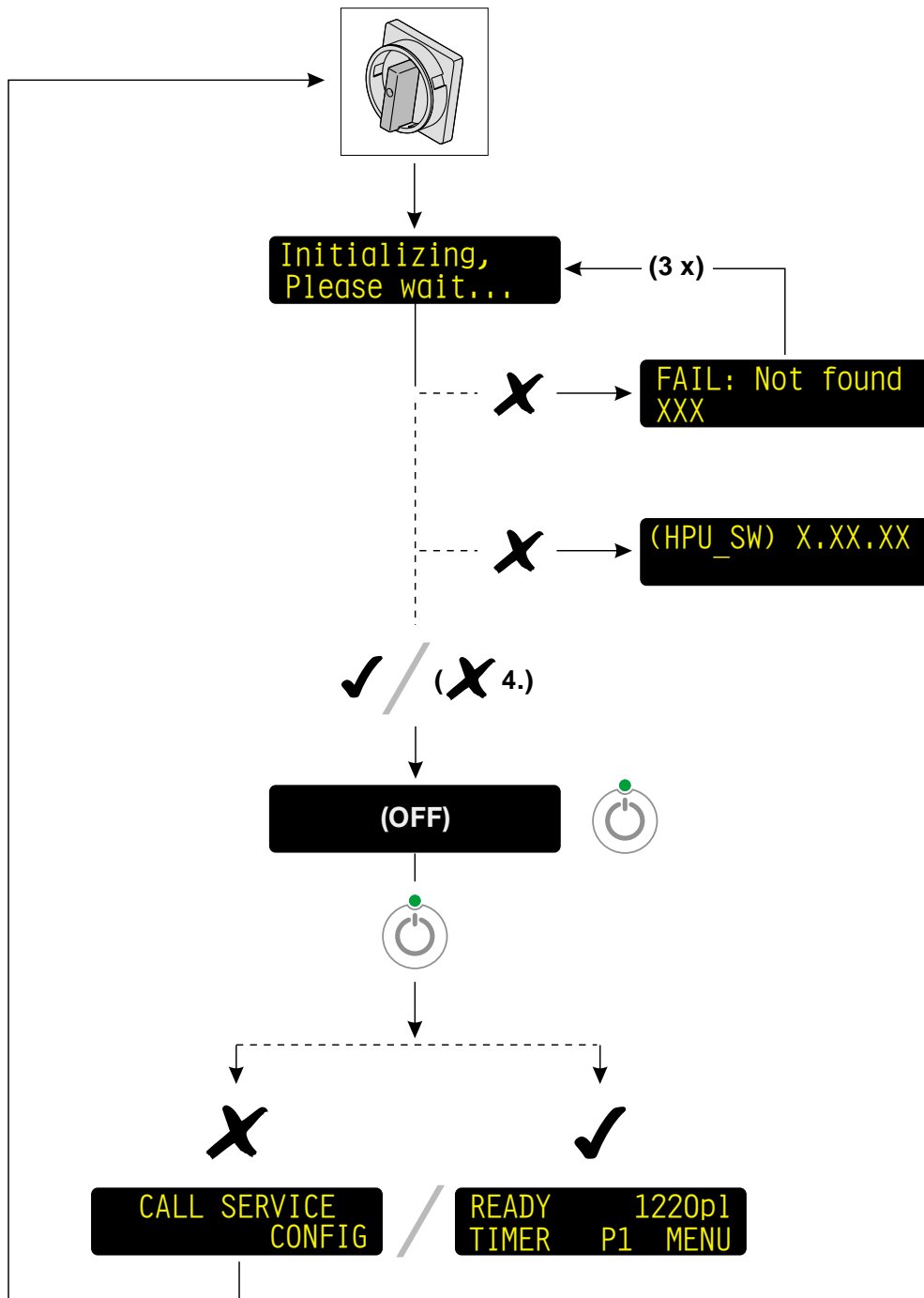

INITIALIZATION FAIL

(See illustration opposite).

When processor is turned on it starts to initialize. The message "FAIL NOT FOUND" might occur during start-up in special situations. Below is described when it might happen.

"FAIL NOT FOUND"

If initialization fails because of a missing or bad connection to one of the circuit boards (**not** the MPU or MMU board) an error message is displayed with an indication of the respective board(s).

The processor will try to initialize 3 times and then it turns into off mode.

Pressing the stand-by key switches the processor into a "safe" mode from where you will have to do the following:

- If display says "CALL SERVICE" turn processor off and call service.
Alternatively turn power off and on to make the processor reconfigure and initialize again and press the standby-key.
- If display says "READY" (or "WAIT" if warming up etc.) the processor has initialized successfully and service will not be needed.

MPT CONTROL PANEL

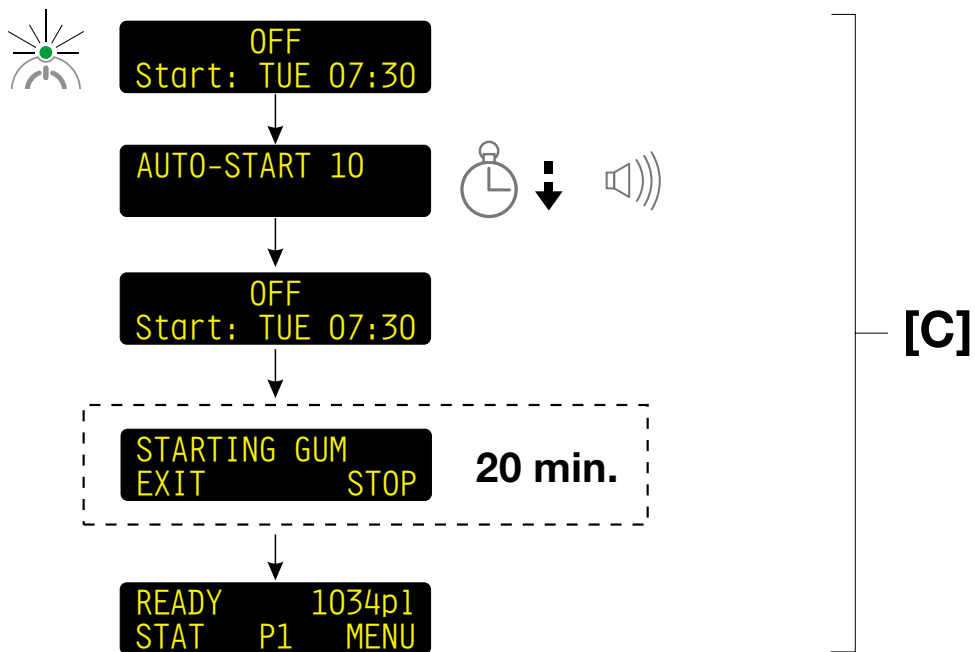
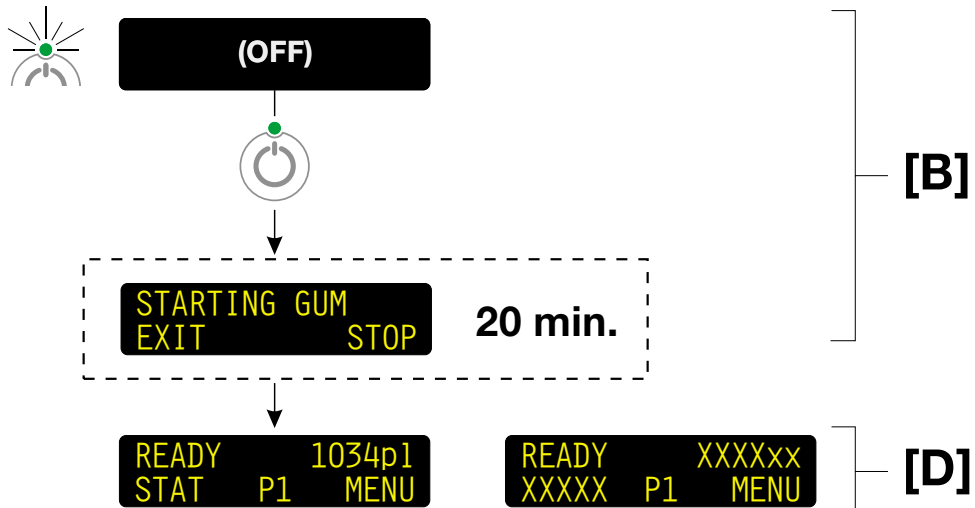

START-UP (Switching into stand-by mode)

There are 2 ways of switching the processor into stand-by mode:

- using the **STAND-BY key**
or
- using the **TIMER function**.

[B] SWITCHING ON USING THE STAND-BY KEY

(See diagram opposite)

- Main power must be on and the processor in off mode (display is black). See "TURNING MAIN POWER ON" on page 1.13.
- Press the stand-by key.
- **a) If gum clean* or gum water replenish pump is set to on:** The display will show "STARTING GUM". The processor will automatically switch into stand-by mode and be ready for processing after warming up.
The "STARTING GUM" message is described in the table "ALARMS AND MESSAGES" in chapter 2.
- **b) If gum clean* is set to off, and if no gum water replenish pump:** The processor switches into stand-by mode and will be ready for processing after warming up.

*) The gum parameter is to be set by a service technician. The gum clean feature automatically cleans the gum section rollers at start-up and shut-down. During the process gum is applied without the rollers turning followed by the rollers turning shortly backwards and then forwards. The procedure takes approx. 20 min. and ensures a uniform gum layer on the first plate to be processed.
It is possible to select processing program and change program settings during the cleaning process.

[C] SWITCHING ON USING THE TIMER FUNCTION

(See diagram opposite)

The processor's timer function enables automatic start-up.

- If timer function is switched on and main power is turned on, the next start-up time will be shown in the bottom line of the display.
- The display will show "AUTO-START X" 10 seconds before start-up and a beeper will beep for a few seconds to advise the operator.
- The processor automatically switches into stand-by mode as described for [B]: paragraph a) or b).

NOTES!

- *It is possible to start-up the processor manually any time even though the timer function is switched on.*
- *Starting the processor manually will override the settings in the timer function. See description of SWITCHING OFF WITH MANUAL TIMER FUNCTION on page 1.19 and AUTO TIMER on page 1.45.*

MPT CONTROL PANEL

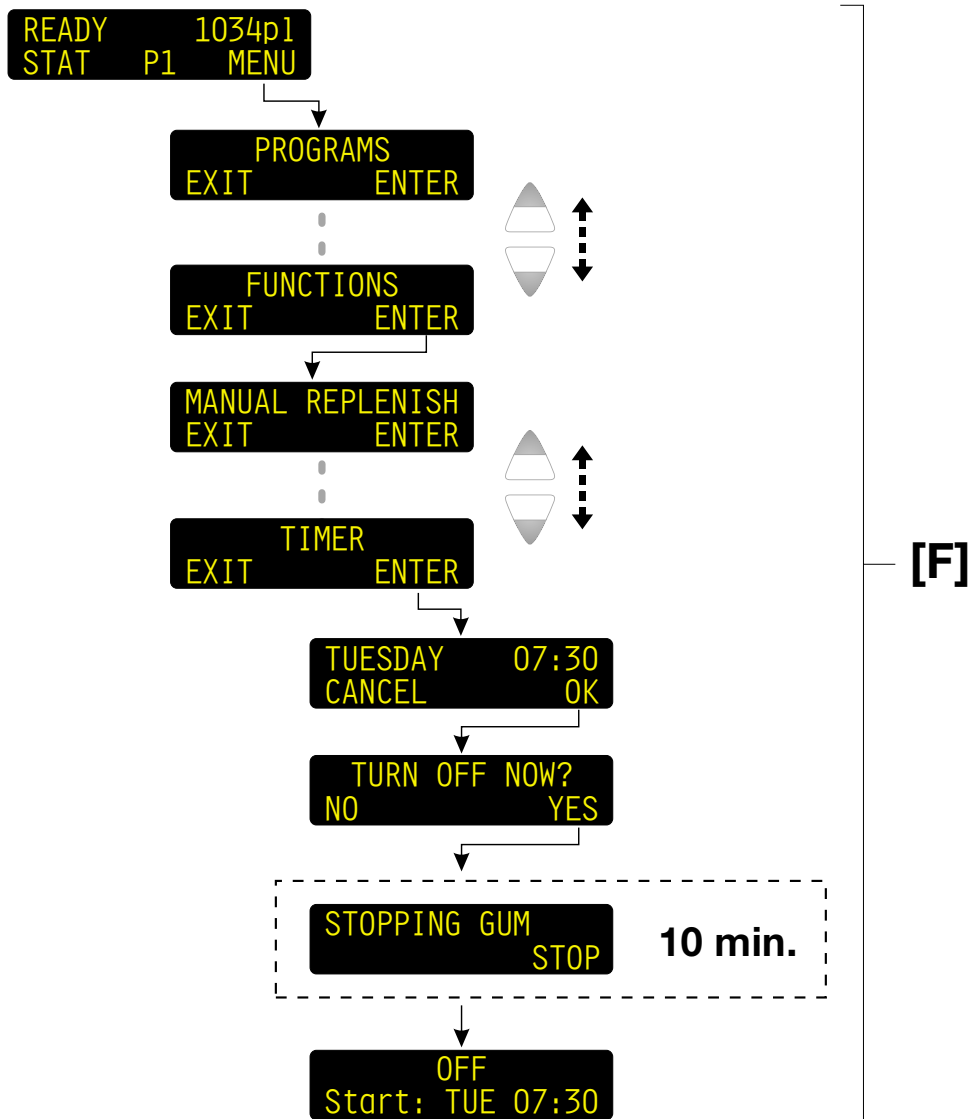
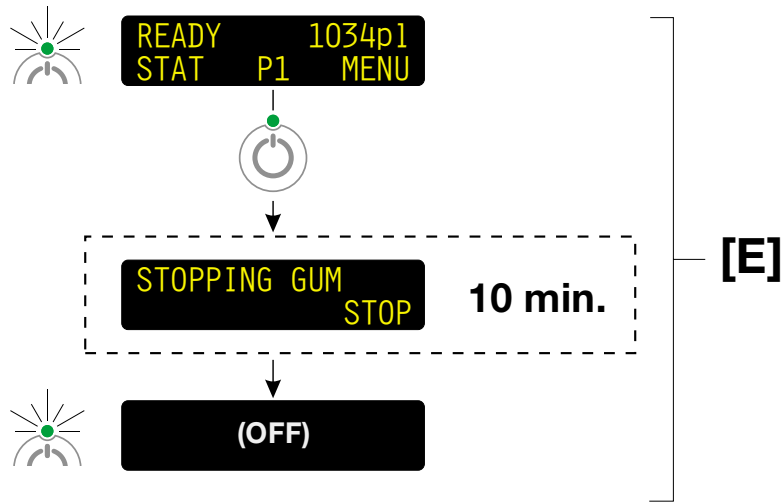

T2567

SHUT-DOWN **(Turn from stand-by to OFF mode)**

There are 2 ways of switching the processor off:

- **Switch OFF without using the manual timer function, or**
- **Switch OFF with manual timer function.**

[E] SWITCHING OFF WITHOUT USING THE MANUAL TIMER FUNCTION

(See upper diagram opposite.)

- From stand-by mode press the stand-by key.
- **a) If gum clean* or gum water replenish pump is set to on** (to be set by a service technician): The display will show "STOPPING GUM". The processor will automatically switch into off mode. "STOPPING GUM" is described in the table "ALARMS AND MESSAGES" in chapter 2.
- **b) If gum clean* is set to off, and if no gum water replenish pump** (to be set by a service technician): The processor switches into off mode.
- All processing functions are now off, but time replenish and timer functions are active (if set to ON).

*) See the note on page 1.17.

[F] SWITCHING OFF WITH MANUAL TIMER FUNCTION

(See lower diagram opposite.)

Using the manual timer function enables you to turn the processor off and at the same time select new day and time for automatic start-up.

- Enter the timer function using the left-key function (if set to TIMER), or
- From stand-by mode press the "MENU" selection key.
- Press down key to select FUNCTIONS.

- Press the "ENTER" selection key to enter FUNCTIONS.
- Press down key to select the TIMER function.
- Press "ENTER" to enter TIMER function.
- The display will show the start-up day. Press "OK" to activate the manual timer function and turn off the processor with the set day and time for next start-up, or change settings:
 - Press the quick-set key to make new start-up settings. A cursor will appear in the top line in the display:
 - Press up/down keys to select another week day on which the processor should automatically start up again and press OK.
 - Press up/down keys to select another hour on which the processor should automatically start up and press OK.
 - Press up/down keys to select another minute on which the processor should automatically start up and press OK.
 - Press OK to activate the TIMER function.
- The message "TURN OFF NOW?" will be prompted. Press "YES" to accept. The processor will switch into off mode and show day and time for next start-up in the display, e.g. "Start TUE 07:30". All processing functions are now off, but time replenish and timer functions are active (if set to ON).
- The manual timer function is also briefly described on page 1.35.
- The processor will automatically start-up on the day and time shown in the display.
- To overrule the timer function simply press the stand-by key and the processor will start-up as shown in example [B].

See also the description of "AUTO TIMER" function on page 1.45.

MPT CONTROL PANEL

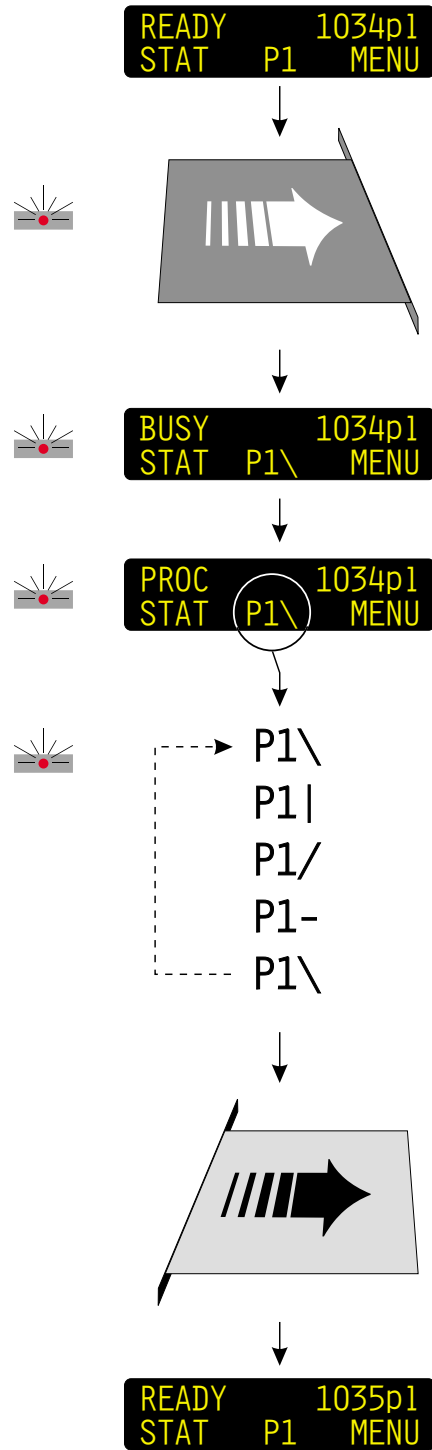

PROCESSING

(See diagram opposite)

- The processor must be in stand-by mode (display shows "READY").
- When a plate is entered, either manually (offline) or automatically (online) the processor switches into process mode:
 - The display will change to show "BUSY".
 - The alarm lamp will be lit.
 - A continuously changing processing symbol behind the selected program number will appear e.g. "P1/".
- A few seconds after the input sensors are released the display will change to "PROC".
- The processor automatically returns to stand-by mode shortly after the last plate exits.

MPT CONTROL PANEL

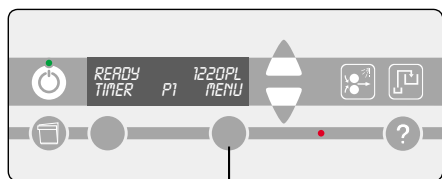

() Parameters in parenthesis are not available on all models.

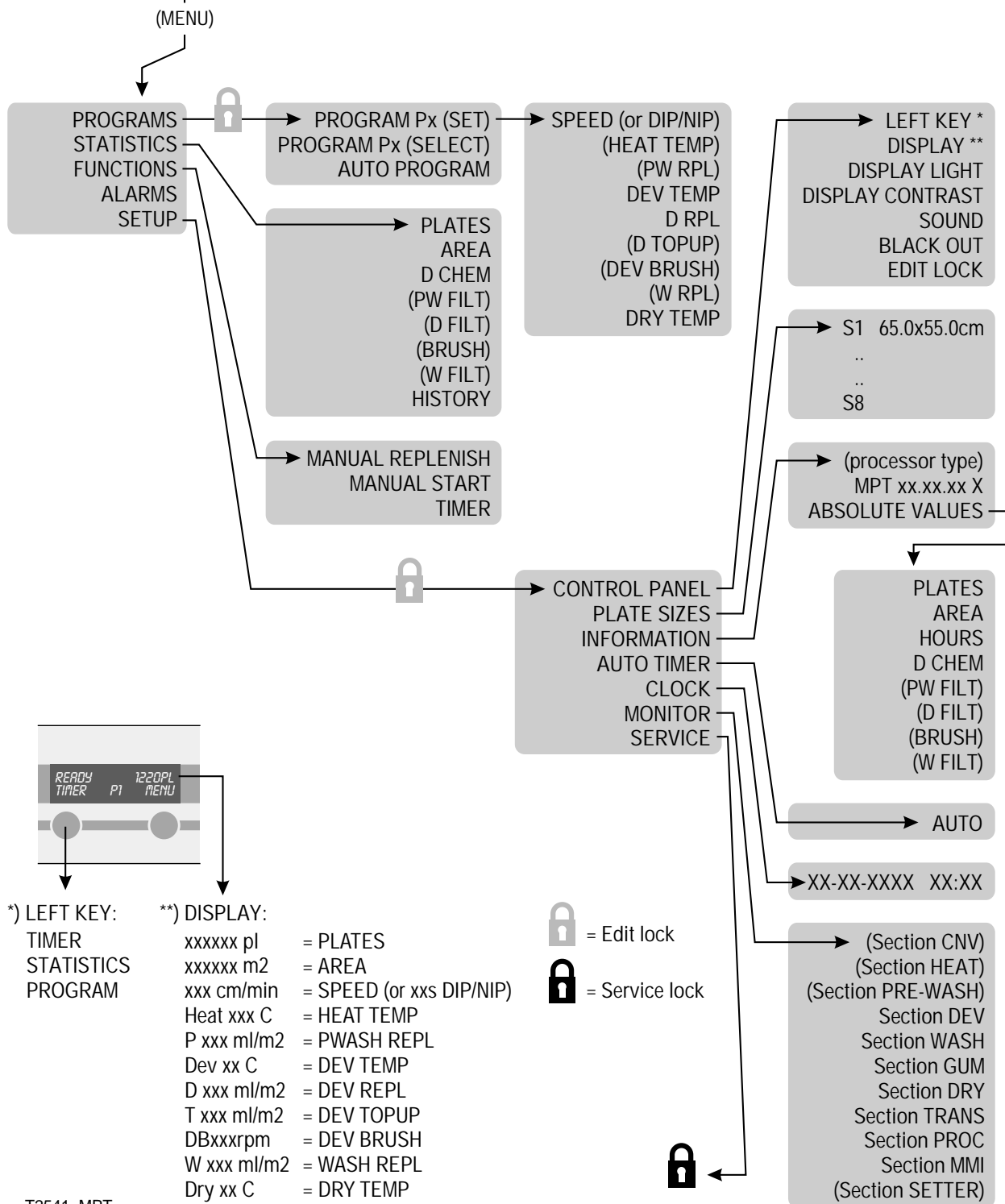

*) LEFT KEY:
TIMER
STATISTICS
PROGRAM

**) DISPLAY:
xxxxxx pl = PLATES
xxxxxx m2 = AREA
xxx cm/min = SPEED (or xxs DIP/NIP)
Heat xxx C = HEAT TEMP
P xxx ml/m2 = PWASH REPL
Dev xx C = DEV TEMP
D xxx ml/m2 = DEV REPL
T xxx ml/m2 = DEV TOPUP
DBxxxrpm = DEV BRUSH
W xxx ml/m2 = WASH REPL
Dry xx C = DRY TEMP

= Edit lock
 = Service lock

T2541_MPT...

DETAILED MENU DESCRIPTIONS

MENU STRUCTURE

(See diagram opposite)

The menu structure shown opposite illustrates the control panel menus available for the daily operator of the plate processor.

NOTE! Parameters in parenthesis are not available on all models.

The subjects of the menu are described in detail on the following pages.

Descriptions are made in the same order as the building up of the menu structure itself.

MPT CONTROL PANEL

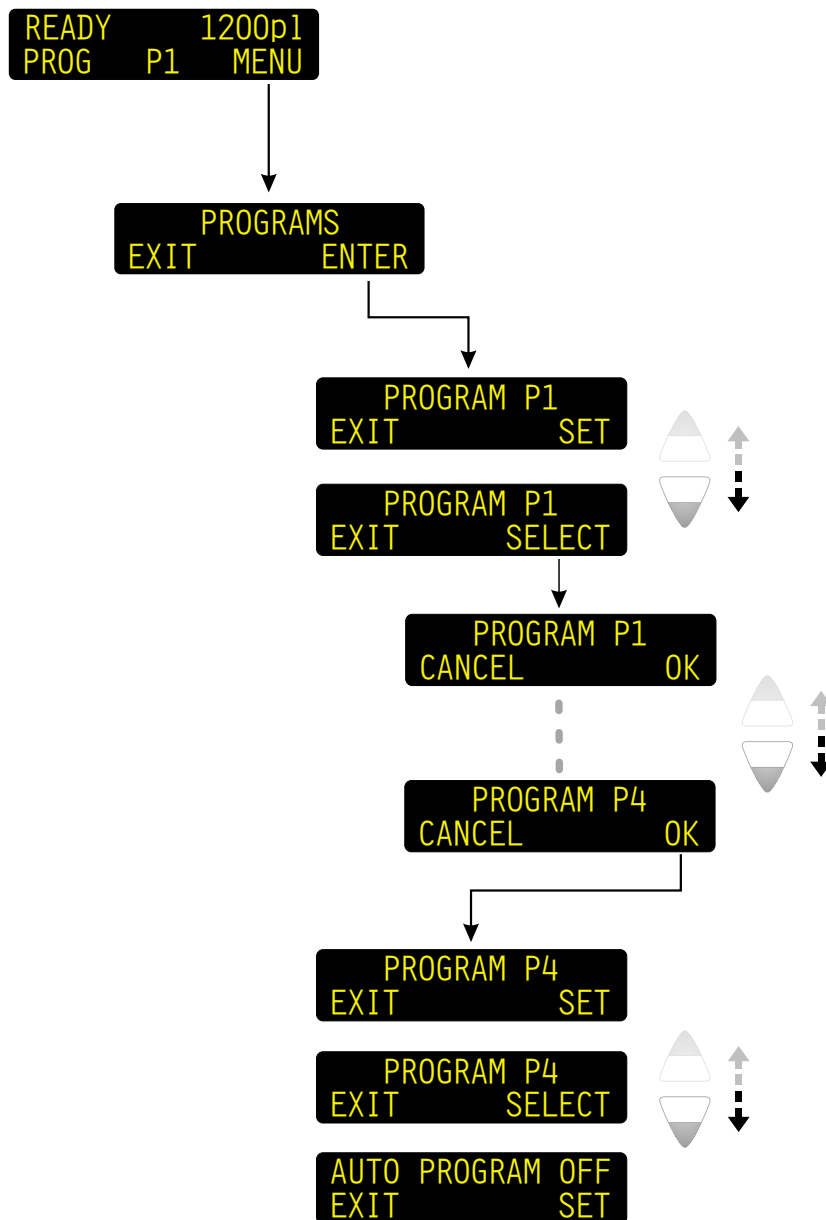

PROGRAMS

It is possible to choose between 4 processing programs, each programmable with different developing times, temperatures, and replenishment settings for various processing jobs.

The table below shows the various program parameters.

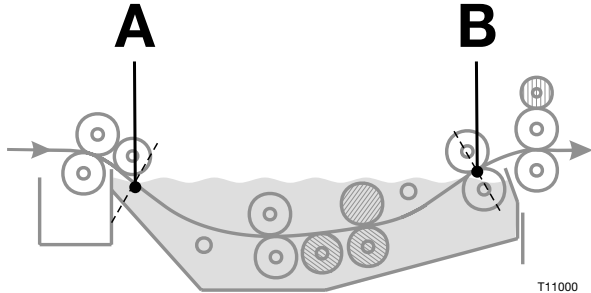
PARAMETER	SETTING	DESCRIPTION
Parameters in bold italic are not available for all processor variants or depending on configuration.		
<i>SPEED*</i>	XX cm/min. (" /min.)	Developing time.
<i>DIP/NIP*</i>	XX s (seconds)	Dip/nip time. The dip/nip time is from the time the plate "dips" into the developer solution (A) till it engages the exit rollers (B) in the developer section.  T11000
<i>HEAT TEMP</i>	XX °C (XX °F)	Temperature of the heat section
<i>PW RPL</i>	XXX ml/m ² (cc/ft ²)	The amount of replenishment added to the pre-wash section per m ² (ft ²) plate processed.
DEV TEMP	XX °C (XX °F)	Temperature of the developer solution.
D RPL	XXX ml/m ² (cc/ft ²)	The amount of replenishment added to the developer section per m ² (ft ²) plate processed.
<i>D TOPUP</i>	XXX ml/m ² (cc/ft ²)	The amount of solution from the developer fill container added to the developer section per m ² (ft ²) plate processed.
<i>DEV BRUSH</i>	XXX rpm	Brush speed set in revolution per minute (rpm).
<i>W RPL</i>	XXX ml/m ² (cc/ft ²)	The amount of replenishment added to the wash section per m ² (ft ²) plate processed.
DRY TEMP	XX °C (XX °F)	Temperature of the dryer air.
*) Only one of these parameters are visible. That is the one configured by the service technician.		
NOTE! Make notes of the settings made in these parameters in the table in chapter 3 in this manual.		

MPT CONTROL PANEL

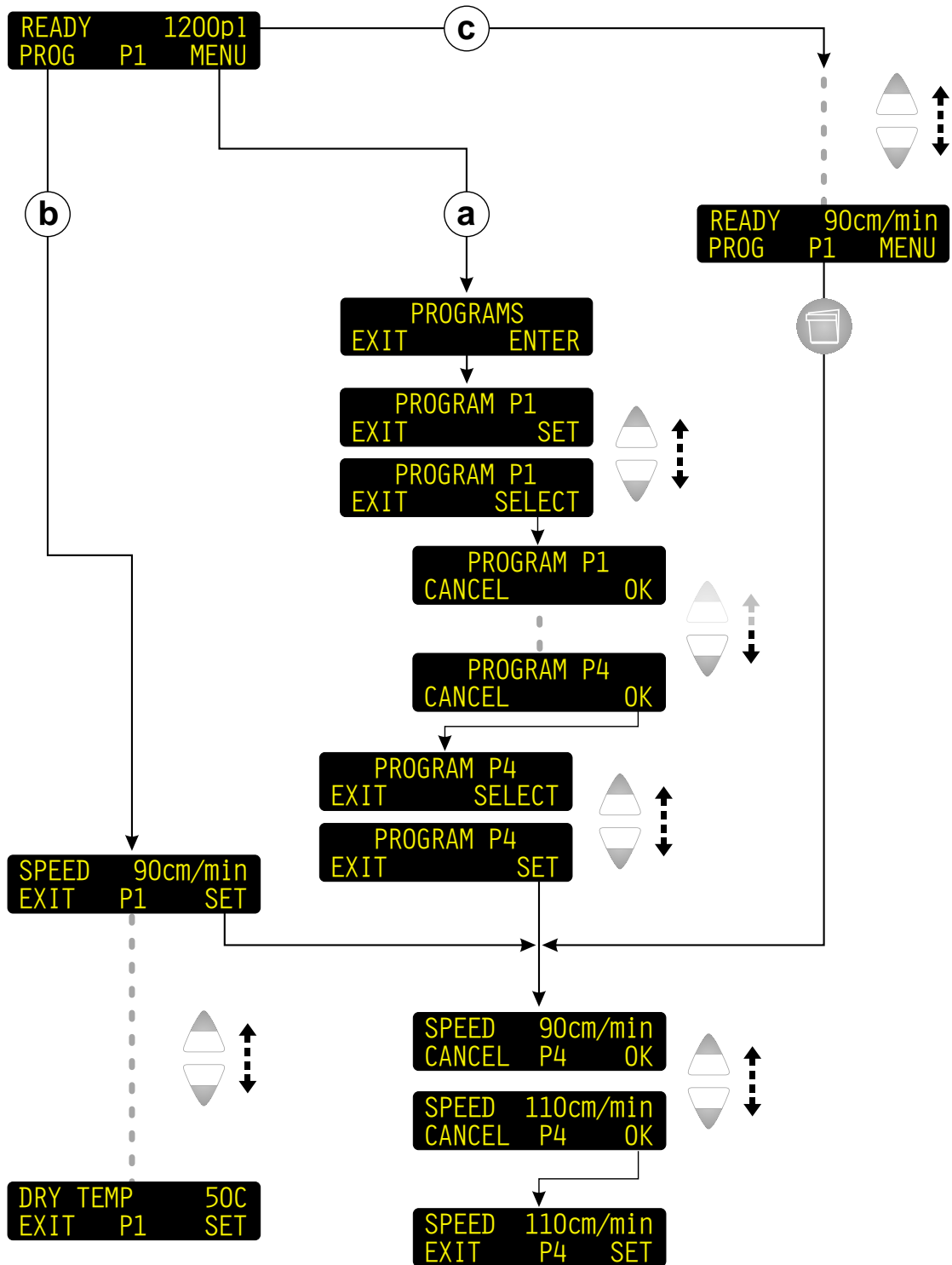

T2578

SELECTING A PROGRAM, OR CHANGING PROGRAM SETTINGS

(See diagram opposite)

a)

- The stand-by display bottom line shows the currently selected program e.g. "P1".
- Enter the PROGRAMS menu and press "ENTER".
- The display now shows the currently selected program with the possibility to enter program settings by pressing "SET".
- To choose another program use the up/down keys to go to the SELECT opportunity. Press "SELECT" and use the up/down keys to select another program number. Press "OK" to confirm.
- Press "EXIT" to exit the programs menu or press the up/down keys to go to "SET" opportunity for making new program settings.
- Press "EXIT" until the display shows the stand-by display. Note that new program number appears in the bottom line.

b)

- If the left selection key is set to "PROG" the program settings can be activated directly by pressing the left selection key when the processor is in stand-by mode.

c)

• QUICK-SET

One of the program parameters listed below can also be selected as a default display setting. See description of "DISP" (display) on page 1.39.

The values of the parameters can then easily be changed by scrolling through the parameter list directly from stand-by mode and pressing the quick-set key.

The display view will automatically return to the parameter selected in "DISP" (display).

MPT CONTROL PANEL

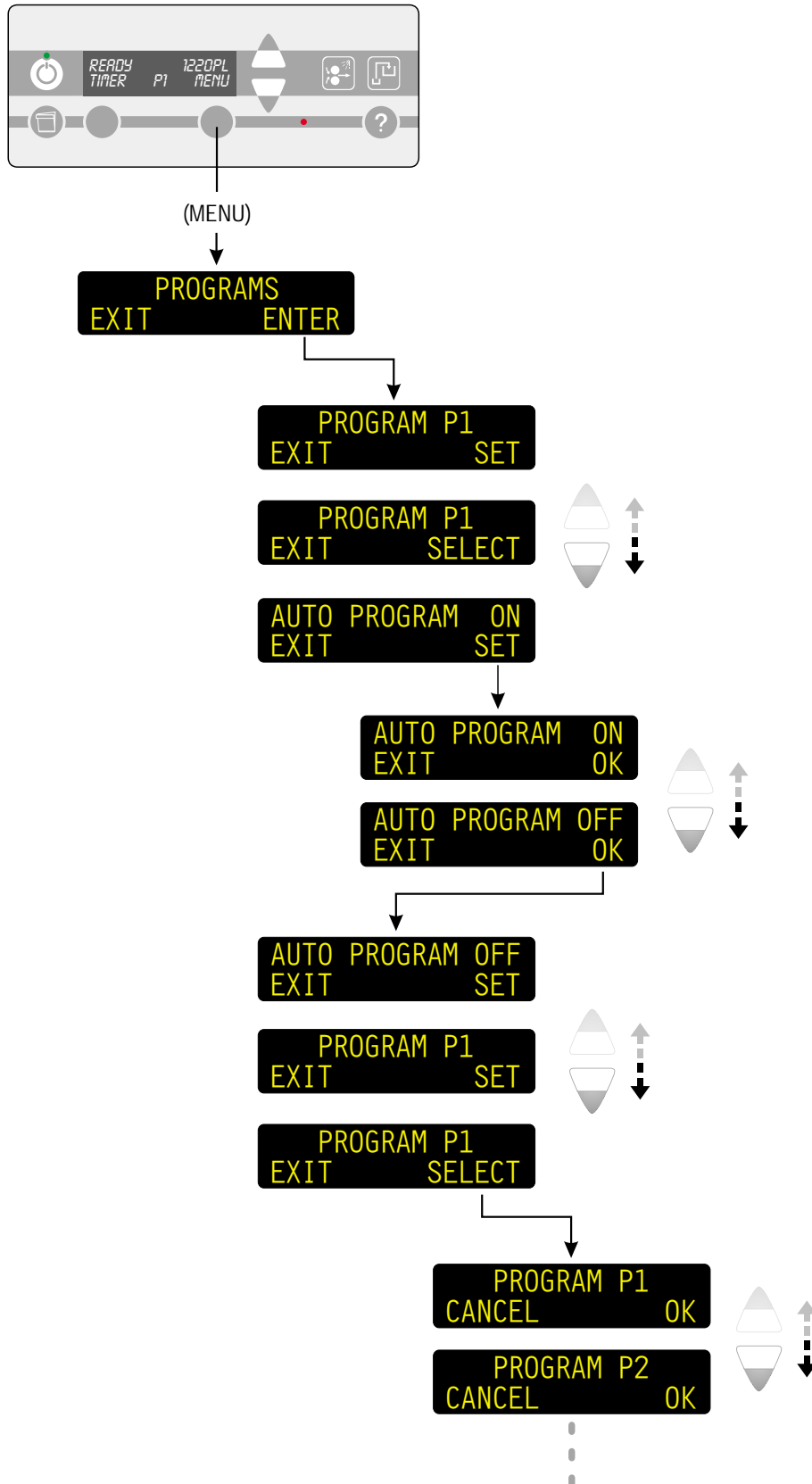

T2619

AUTO PROGRAM

Some online processors are configured for program selection from the setter.

The auto program function allows the operator temporarily to override the program selected through the setter interface by setting auto program to OFF.

Follow the procedure below to switch auto program function off:

- Enter the PROGRAMS menu and press "ENTER".
- The display now shows the currently selected program.
- Use the up or down key to scroll to the AUTO PROGRAM function. Press "SET" to change setting.
- Use the down key to select "OFF" and press "OK".
- Press the up or down key to scroll to the selected program. Display must show program no and "SELECT".
- Press "SELECT" and use the up/down keys to select another program number. Press "OK" to confirm.
- Press "EXIT" twice to return to stand-by mode.

To switch auto program on manually follow the same procedure and set auto program to ON. When set to ON program selection can no longer be made from the control panel but is done from the setter.

The auto program will automatically return to ON if power has been switched off.

MPT CONTROL PANEL

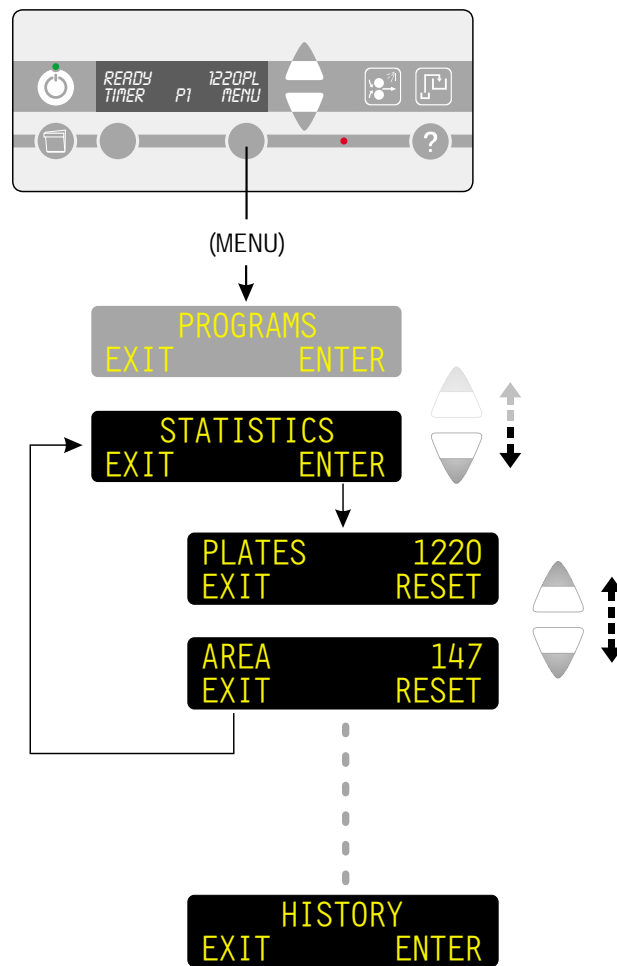

STATISTICS

The statistics function can be used for viewing and resetting the values for the parameters listed below.

This function is useful if information of the total values is needed for specific periods e.g. each week or month.

See also "DISP" (display) on page 1.39.

PARAMETER	DESCRIPTION
Parameters in bold italic are not available for all processor variants or depending on configuration/replace periods.	
PLATES	Total number of plates processed since counter reset.
AREA	Total area processed since counter reset.
<i>D CHEM</i>	Area of plate (in m ²) left to be processed until developer solution change is required. If displayed value is negative (-) the processed plate area has exceeded the max. setting.
<i>PW FILT</i>	Area of plate (in m ²) left to be processed until pre-wash filter change is required. If displayed value is negative (-) the processed plate area has exceeded the max. setting.
<i>D FILT</i>	Area of plate (in m ²) left to be processed until developer filter change is required. If displayed value is negative (-) the processed plate area has exceeded the max. setting.
<i>BRUSH</i>	Length of plate (in m) left to be processed until change of brushes is required. If displayed value is negative (-) the processed plate area has exceeded the max. setting.
<i>W FILT</i>	Area of plate (in m ²) left to be processed until wash filter change is required. If displayed value is negative (-) the processed plate area has exceeded the max. setting.
HISTORY	<i>NOTE! For service purposes.</i> This parameter displays a list with the last 10 changes in software configuration, unexpected system behaviors, etc.

MPT CONTROL PANEL

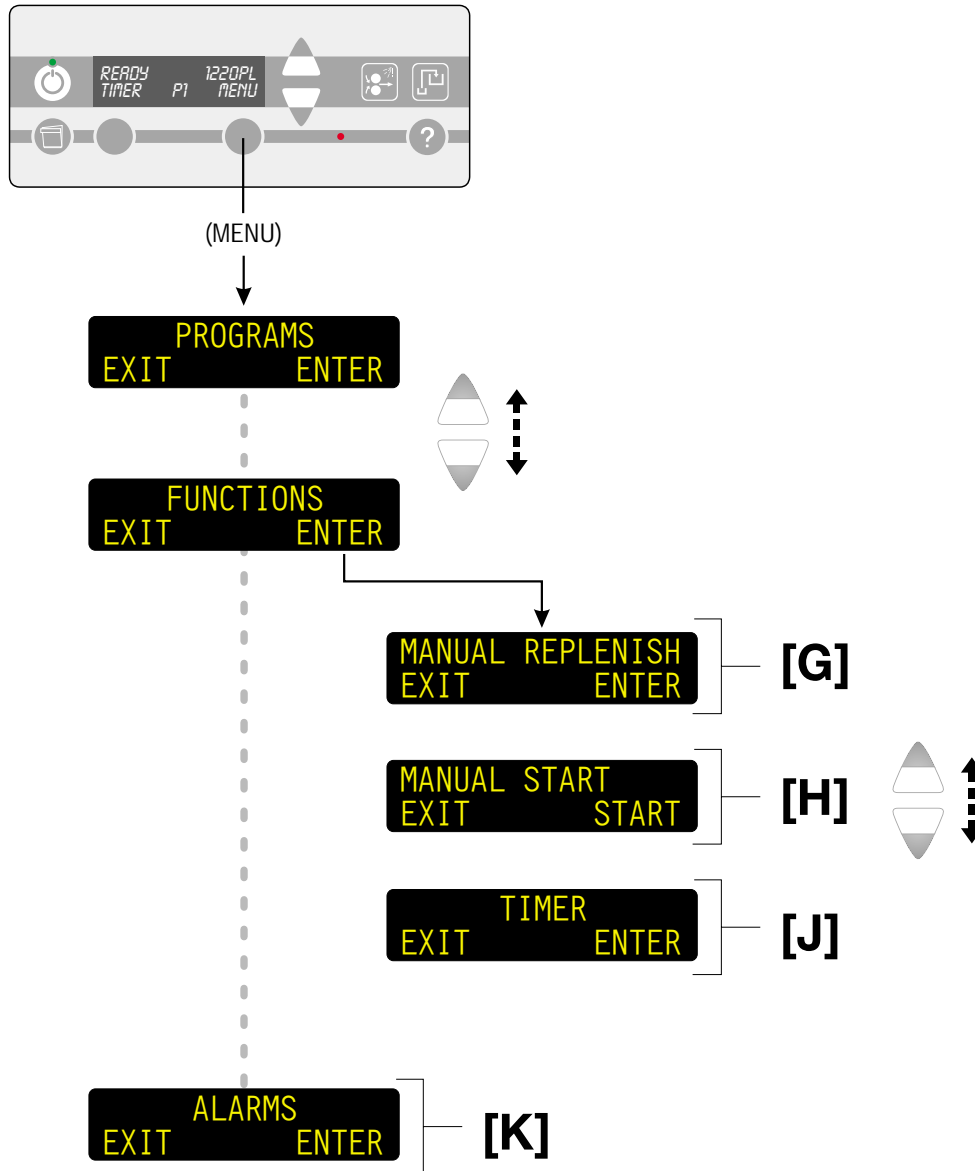

FUNCTIONS

The functions settings are parameters which are not directly related to the processing programs.

[G] MANUAL REPLENISH

This function is identical to the manual replenish key.

See description of the "MANUAL REPLENISH KEY" on page 1.7.

[H] MANUAL START

The manual start function is identical to the manual start key (see page 1.7).

This function is used for the following purposes:

- rewash,
- rinse process, or
- eject of plate material.

Rewash

When activating the manual start function plates can be entered through the rewash slot for rewashing:

- Press "START" and the processor switches into process mode. The display shows "MAN.START".
- Enter a plate through the rewash slot. When the plate reaches the output sensor the display will show "STOP CONTINUE".
- If another plate is going to be rewashed press "CONTINUE" otherwise press "STOP". If the control panel is not activated the processor will automatically return to stand-by mode after a while.

CAUTION! Do not press "STOP" while plate material is in the processor.

Rinse process

When a major cleaning procedure has been performed it is recommended to use the function to make a final rinse of the processor. See cleaning procedure in the "Plate Processor User Manual".

- When pressing "START" the processor switches into process mode for 30 min. The display shows "MAN.START".
- Let the process run until display shows "READY".
- It is possible to shorten the processing cycle manually and return to stand-by mode by pressing "STOP".

Eject of plate material

Use the manual start function to remove a plate left in the processor due to e.g. power failure.

CAUTION! Plates jammed in the processor must be removed manually.

- Press "START" to activate the function.
- The plate will be transported out of the processor.
- When the plate has left the processor press "STOP" to return to stand-by mode.

MPT CONTROL PANEL

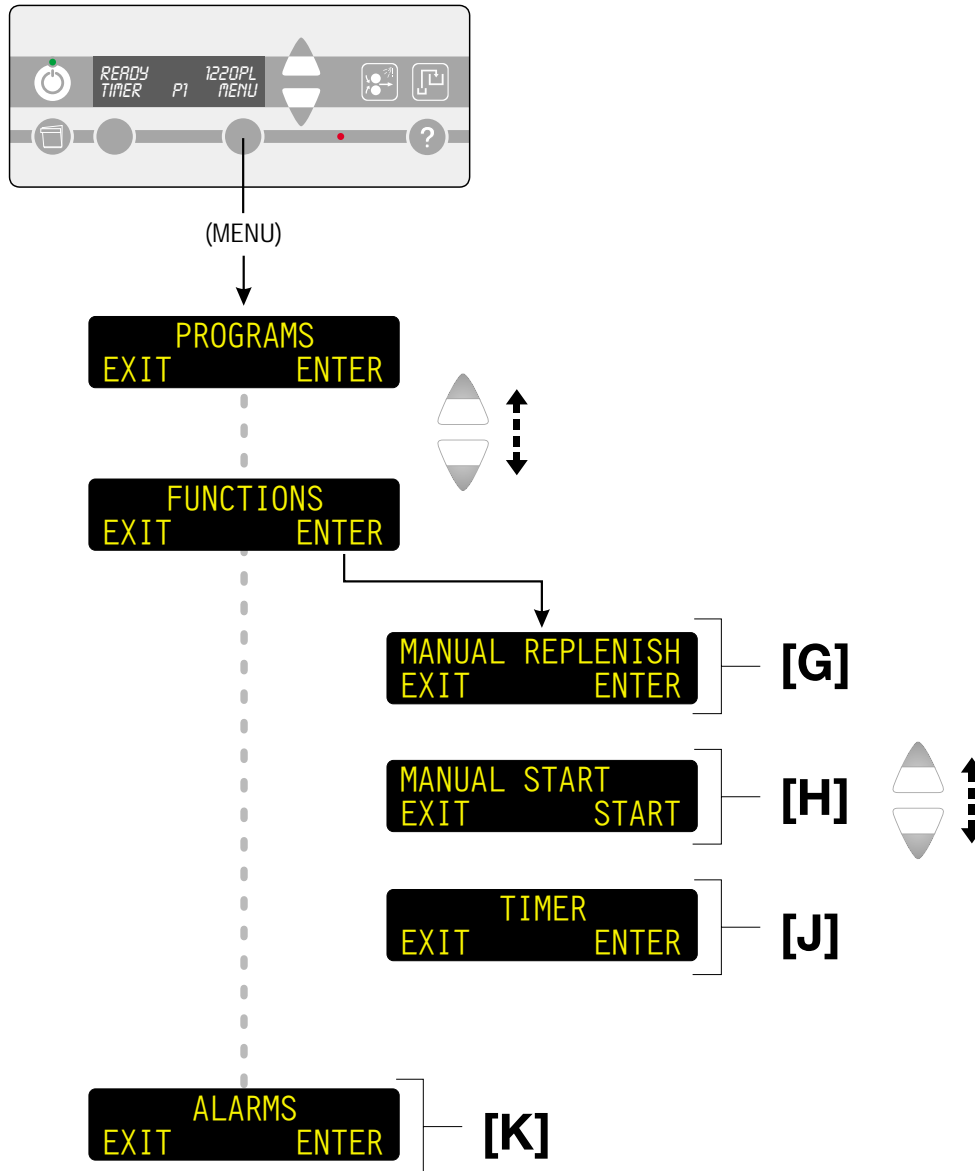

[J] TIMER (MANUAL)

(See diagram opposite)

The manual timer function enables you to turn the processor off and at the same time select new day and time for automatic start-up.

The manual timer key is only used in shut-down situations. Using the manual timer key overrules the settings made in the AUTO TIMER function.

Detailed description of using the manual timer key is made in "SWITCHING OFF WITH MANUAL TIMER FUNCTION" on page 1.19.

NOTES!

- *It is possible to start-up the processor manually any time even though the timer function is switched on.*
- *Starting the processor manually will override the settings in the timer function.*

See also description of the "AUTO TIMER" function on page 1.45.

[K] ALARMS

When the processor is in stand-by mode or is processing, a number of alarms and messages can occur.

When one or more alarms occur you can enter this function to see the description of the different alarms or use the help-text key as described on page 1.9.

A complete list of alarms is included in chapter 2 in this manual. The list includes detailed description of the various alarms and how to act in case an alarm occurs.

See chapter 2 for more information about "ALARMS AND MESSAGES".

MPT CONTROL PANEL

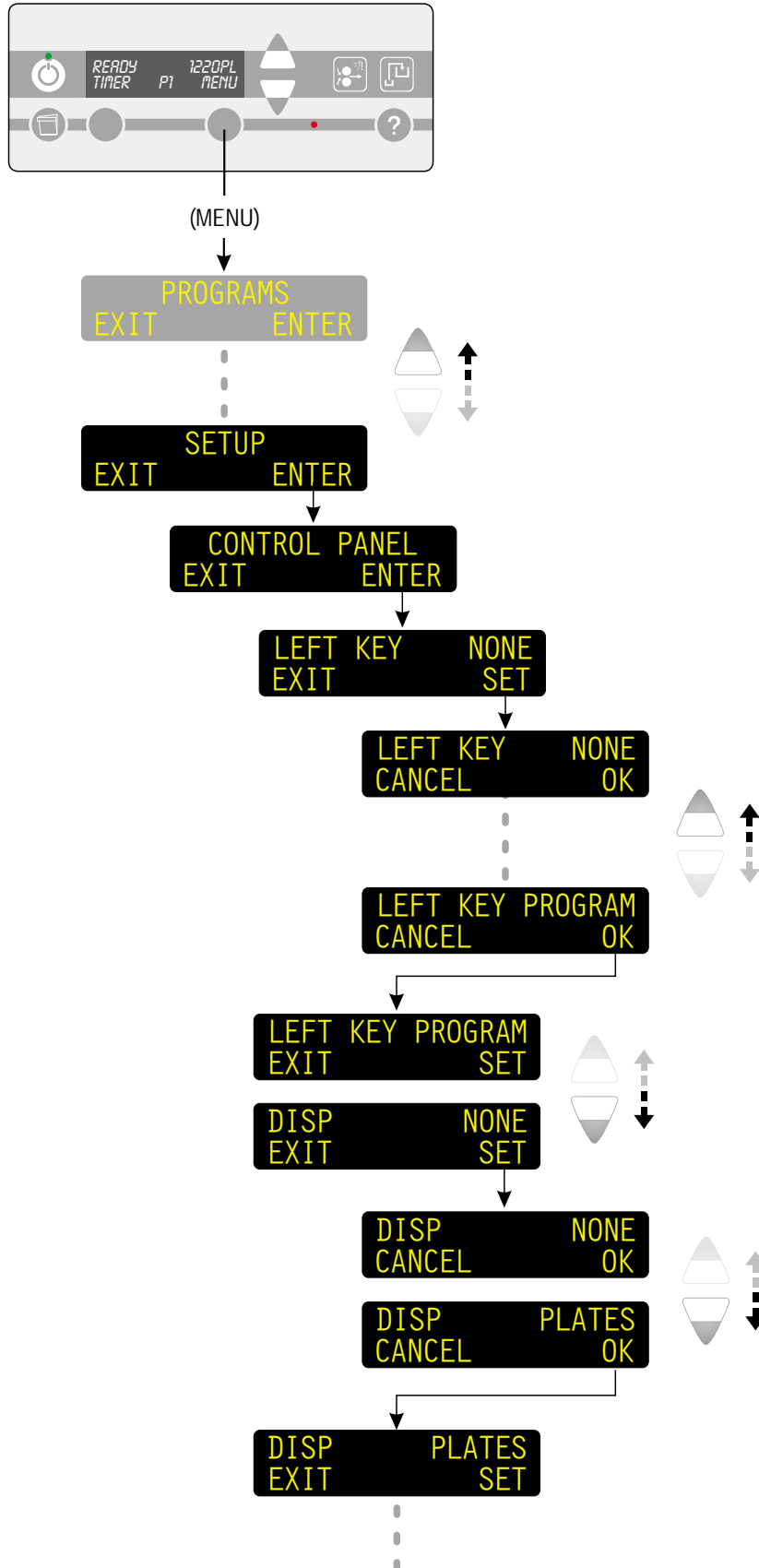

T2571

SETUP

CONTROL PANEL

The control panel functions and parameters are settings in general and thus not directly related to processing.

Make a note of the parameter settings made in the control panel menu in the table in chapter 3.

LEFT KEY

(See diagram opposite)

The function assigns a manual function to the left selection key on the stand-by display.

The assigned function can be executed by pressing the left selection key when the processor is in stand-by mode.

Below is described the available settings:

SETTING	FUNCTION
STAT	(Statistics) When assigned to statistics function the left key will display total amount of processed plates and total amount of processed m ² (ft ²). Use the up/down arrow keys to scroll.
TIMER	When assigned to the manual timer function pressing the left key will jump directly to the timer menu. See MANUAL TIMER on page 1.35 for detailed instructions.
PROG	(Program settings) When assigned to program the left key will give direct access to settings for the active program. Use the up/down arrow keys to scroll through the different settings. See PROGRAMS on page 1.25 for detailed description of program settings.

MPT CONTROL PANEL

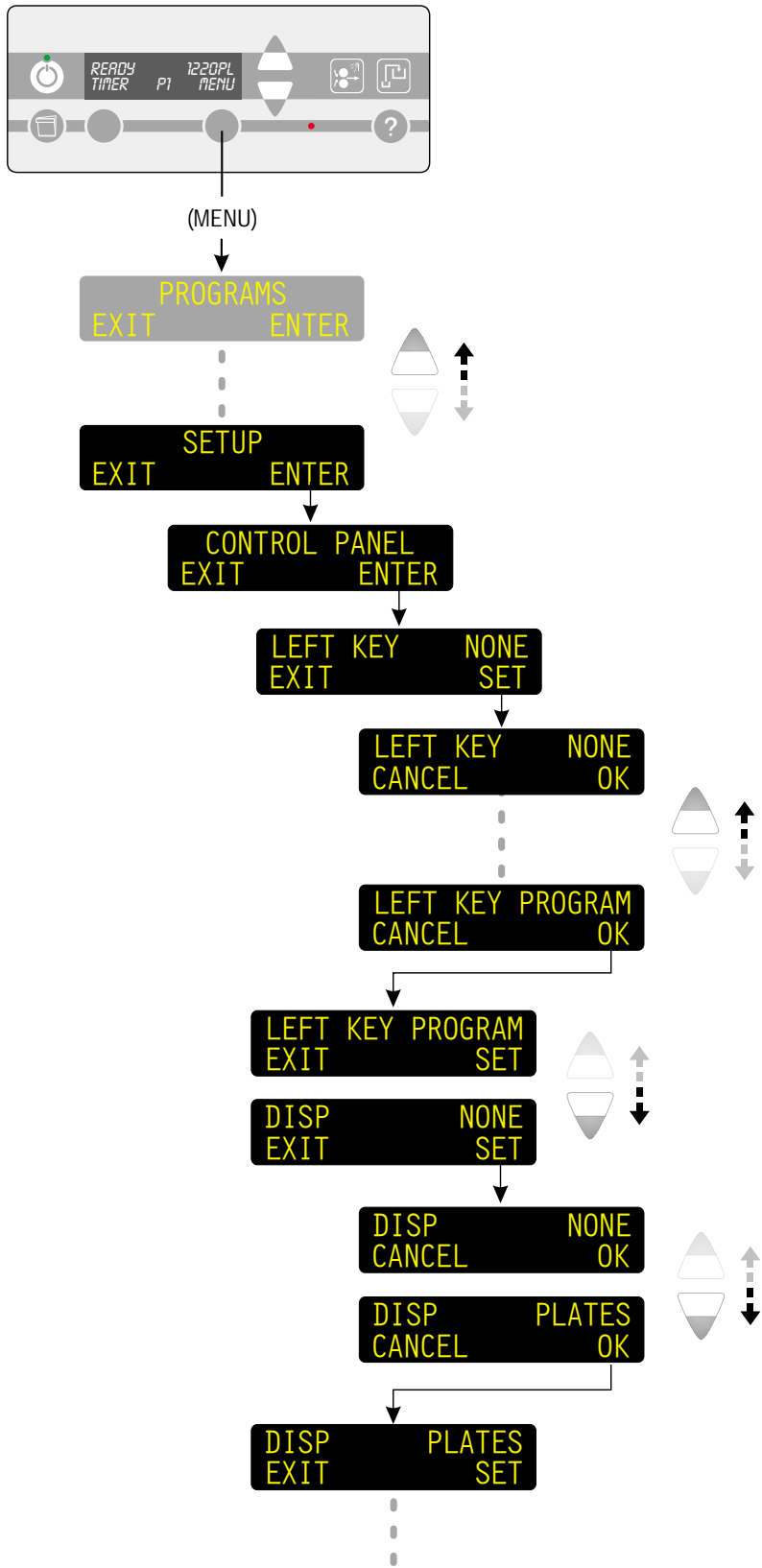

T2571

MPT CONTROL PANEL

DISP (DISPLAY)

The upper right corner of the stand-by display show one of the below listed settings. In DISP you can make you own choice of which one to display as default. All settings can be viewed in the stand-by display by pressing the up/down keys. The display will automatically return to the default setting, e.g. "PLATES". Values can also be changed or reset using the quick-set key.

SETTING	DISPLAY WILL SHOW
Parameters in bold-italic are not available for all processor variants or are depending on configuration.	
PLATES	Total number of plates processed (xxxxxxpl).
AREA	Total amount of m ² processed (xxxxxxm ²).
SPEED	Actual speed (xxx cm/min) as set in the program settings.
DIP/NIP	Dip/nip time as set in the program settings.
HEAT TEMP	Heat section temperature (HeatxxC) as set in the program settings.
PWASH REPL	Pre-wash replenish in ml/m ² (PWxxxml/m ²) as set in the program settings.
DEV TEMP	Developer temperature (DevxxC) as set in the program settings.
DEV REPL	Developer replenish in ml/m ² (Dxxxml/m ²) as set in the program settings.
D TOPUP	Developer top-up in ml/m ² (Txxxml/m ²) as set in the program settings.
DEV BRUSH	Developer brush speed in rpm (revolutions per minute).
WASH REPL	Wash replenish in ml/m ² (Wxxxml/m ²) as set in the program settings.
DRY TEMP	Dryer temperature (DryxxC) as set in the program settings.

MPT CONTROL PANEL

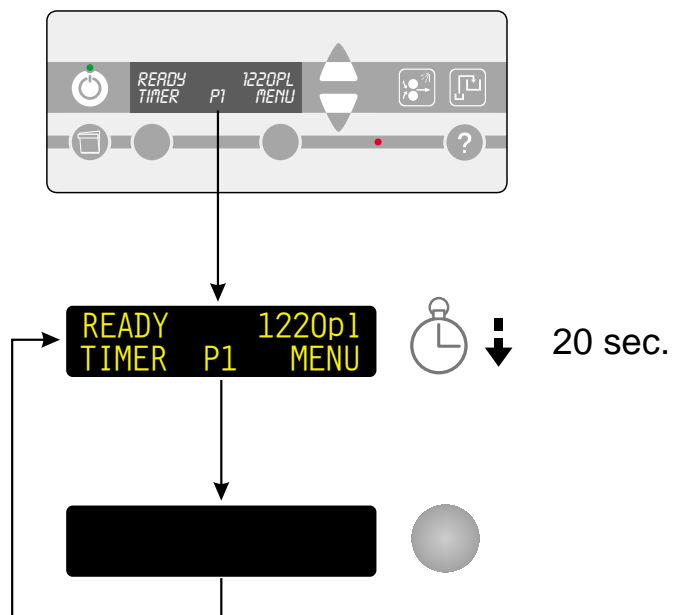
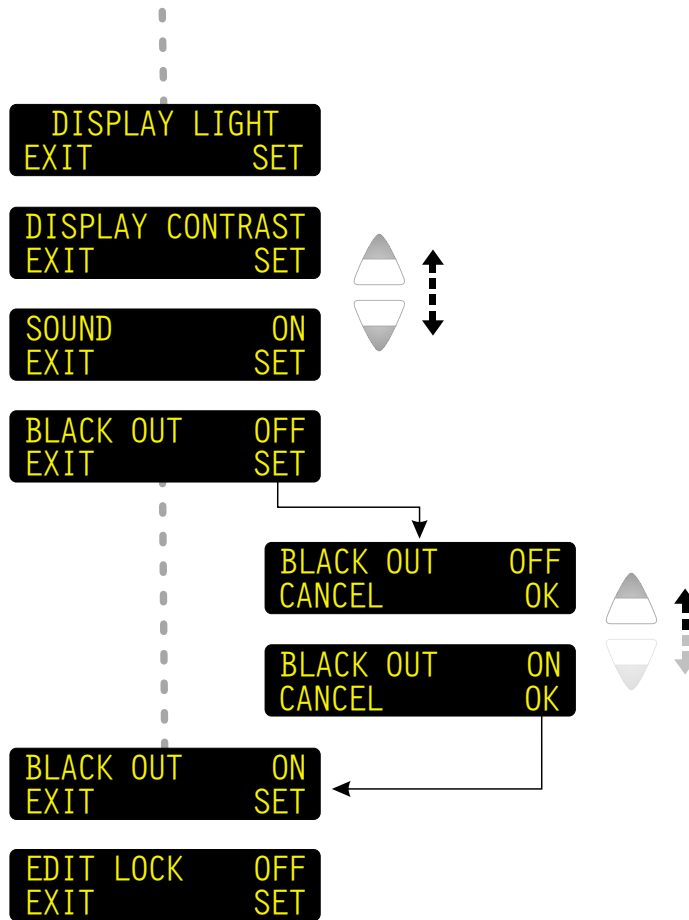

T2579

DISPLAY LIGHT DISPLAY CONTRAST

(See upper diagram)

Use these functions to adjust the display light intensity and contrast:

- Press "SET" to enter the function.
- Use the up/down keys to make the adjustment and when finished press "OK".

For totally black out of the display see description of the BLACK OUT function opposite.

SOUND

(See upper diagram)

Use this function to select whether the beeper should sound or not.

When set to ON the beeper will sound:

- If an important alarm (ex. waste full) occurs.
- When the input sensor(s) is deactivated and the processor is ready to process. (**Offline installations only**).

Exceptions:

The sound functions described below will be active no matter which setting is made in SOUND:

- When display black out function is active the beeper will sound for all types of alarms. See BLACK OUT opposite.
- When the processor is in off mode:
 - The beeper will sound when the top cover has been opened and closed.
The display will show "Turning - Wait" and the rollers will turn briefly for cleaning purpose.

BLACK OUT

(See lower diagram)

When set to "ON" the black out function will turn off all display lights automatically after a period of 20 sec. stand-by time provided that the key pad had not been touched in those 20 sec.

This function is useful when working with light sensitive materials in a darkroom.

To turn on the light again simply press any key.

EDIT LOCK

(See upper diagram)

When edit lock is set to "ON" it is not possible to enter the PROGRAM and SETUP menus, nor is it possible to change program settings using the quick set key.

Only authorized personnel should be familiar with the code to break the edit lock.

The code for opening the program and the setup menus is: up key, down key, "YES":

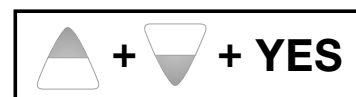

T31520

MPT CONTROL PANEL

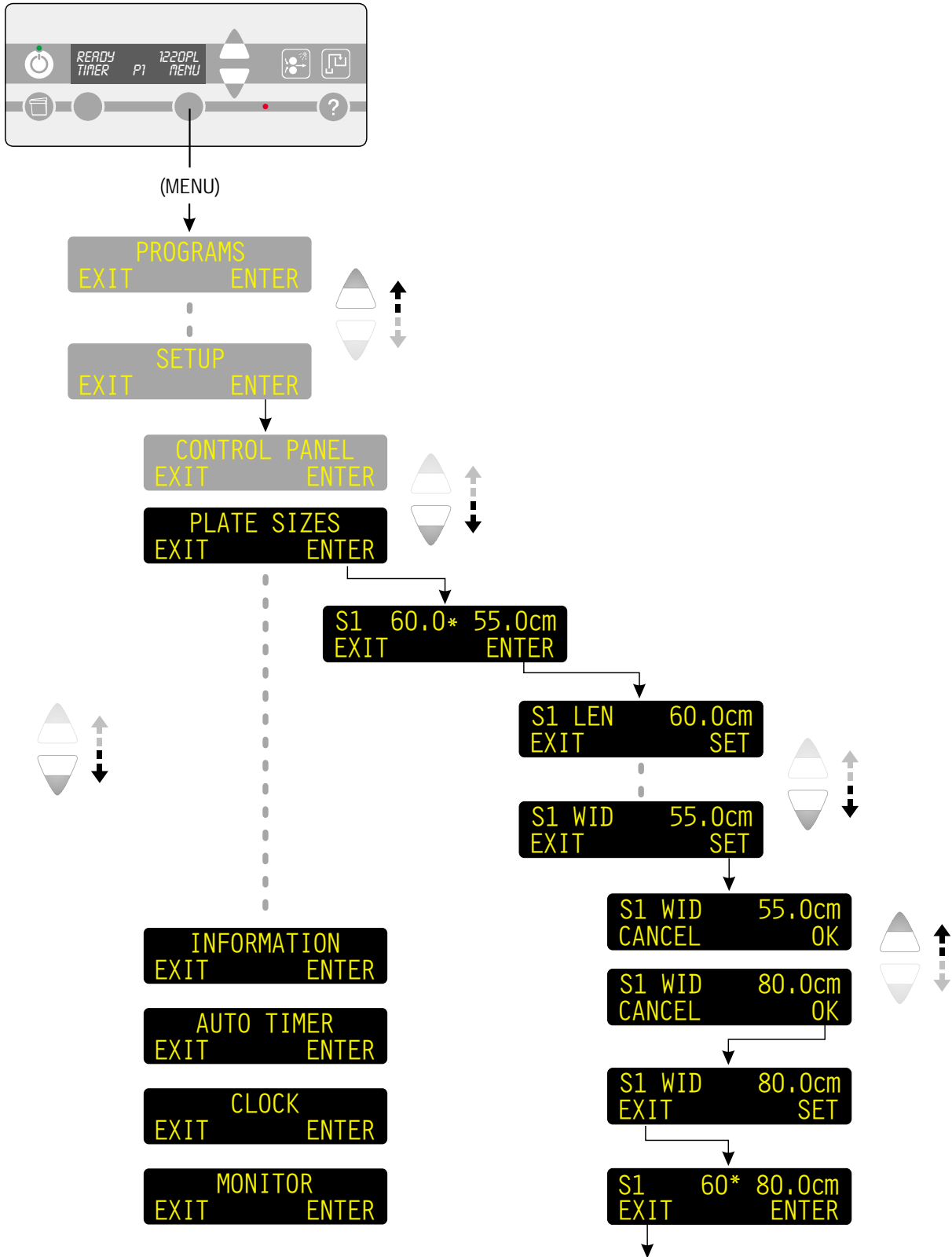

T2581

MPT CONTROL PANEL

PLATE SIZES

(See diagram opposite.)

It is possible to enter 8 different sizes for plates. Length (LEN) and width (WID) are entered separately.

INFORMATION

The information menu holds information which is useful for a service technician. Pass on the information to the service company when asking for a service visit:

- Processor type
- Software version
- Absolute values

ABSOLUTE VALUES

In absolute values you can view and set values for:

PARAMETER	DESCRIPTION
Parameters in bold italics are not available for all processor variants or dependent of configuration/replace periods.	
PLATES	Total amount of plates processed.
AREA	Total processed plate area.
HOURS	Total number of processing hours.
<i>D CHEM</i>	Total area of plate left to be processed until developer solution change is required.
<i>PW FILT</i>	Total area of plate left to be processed until cleaning of or changing pre-wash filter is required.
<i>D FILT</i>	Total area of plate left to be processed until developer filter change is required.
<i>BRUSH</i>	Total area of plate left to be processed until developer brush change is required.
<i>W FILT</i>	Total area of plate left to be processed until wash filter change is required.

Make a note of the settings in the table in chapter 3.

MPT CONTROL PANEL

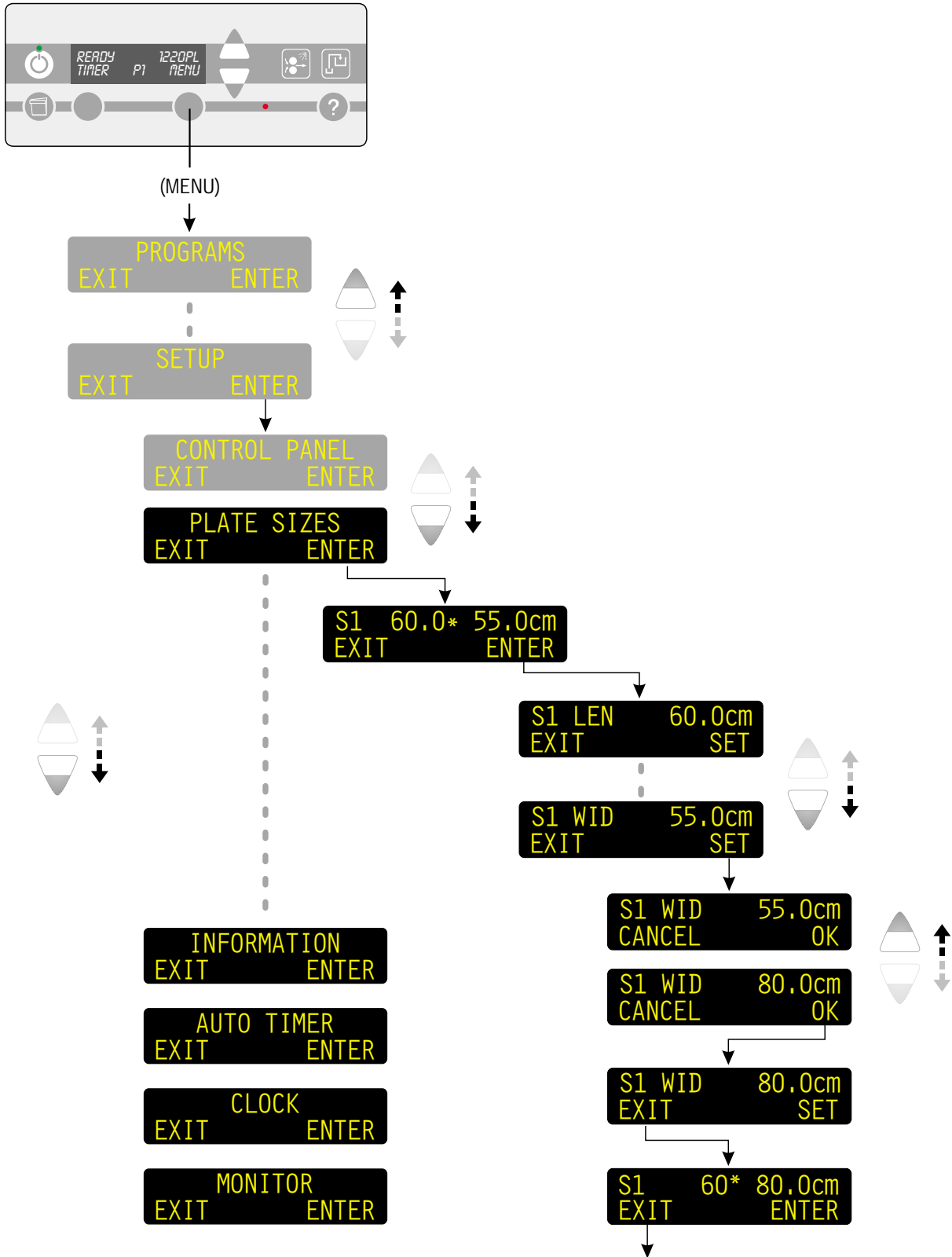

T2581

AUTO TIMER

The auto timer function makes the processor start up automatically every day on a set time.

If the processor is set to auto timer function but not supposed to start up during holidays etc. use the manual timer function to switch the processor off and at the same time select the next start-up day and time manually.

Follow this procedure for setting up the auto timer function:

- Select the AUTO TIMER function and press "ENTER".
- Press "SET" to make settings.
- Press the up key to change setting from off to "ON".
- If new settings for daily start-up time is required press up/down keys to change setting for minutes. Press "OK" to confirm.
- Press up/down keys to change setting for hours. Press "OK" to confirm and exit the set-up menu.
- Press "EXIT" to exit the auto timer function.
- To execute the auto timer function simply switch the processor into off mode as described in "SHUT-DOWN" on page 1.19.
- The processor will now start up automatically on the next day at the time set in the auto timer function.

NOTE! Starting the processor manually before it automatically starts up will overrule the settings in the auto timer function.

Make a note of the settings in the table in chapter 3.

MPT CONTROL PANEL

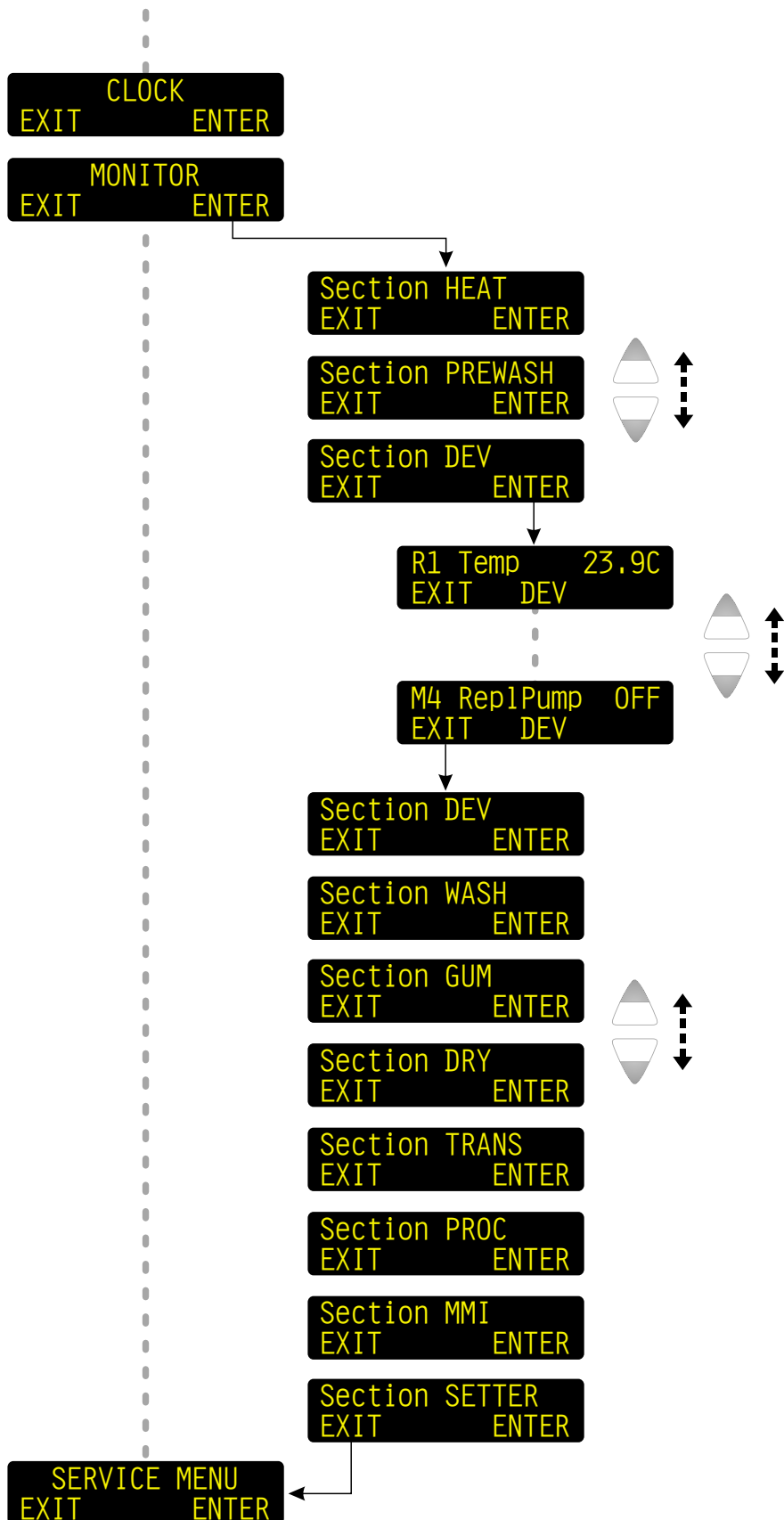

T2582

MPT CONTROL PANEL

CLOCK

In the clock function are made settings for both date and time.

Make sure settings are made accurately otherwise the timer function and the auto timer function will not start the processor at the expected time.

- Press "SET" to make changes in the clock function.
- Press the up/down arrow keys to change the settings - from the right to the left: minutes, hours, year, month and date separately.
- Confirm with "OK" each time to save each change.
- When setting for date is made, "OK" automatically exits the set-up.
- Press "EXIT" to exit the clock function.

NOTE! In order to adjust the internal clock the processor will restart when pressing "EXIT" to leave the clock function.

MONITOR

(See diagram opposite.)

In the monitor function status of bath temperatures, level sensors, heaters and pumps etc. can be displayed for each section separately.

SERVICE

(Service technicians only.)

MPT CONTROL PANEL

2. ALARMS AND MESSAGES

GENERAL

WAIT, BUSY, ALARM ETC.

When the processor is in stand-by mode or is processing different types of status, alarms and messages will be shown in the control panel display.

In this chapter you will find:

- **STATUS MESSAGES.** A complete list with description of status messages combined with alarm lamp behavior and sound signals.
- **ALARMS AND MESSAGES.** A complete list of alarms and messages that might be displayed on the control panel.
- **ALARM DISPLAY.** Detailed description of how to read and handle alarms and messages.

MPA/MPT/EPS CONTROL PANEL

Alarms

STATUS MESSAGES

In the upper left corner of the display is shown the status of the processor (1). In some situations also the alarm lamp (2) is lit or is flashing.

In the table opposite are explained the different status messages and the behaviors of the alarm lamp.

See also "DISPLAYING ALARMS" later in this chapter.

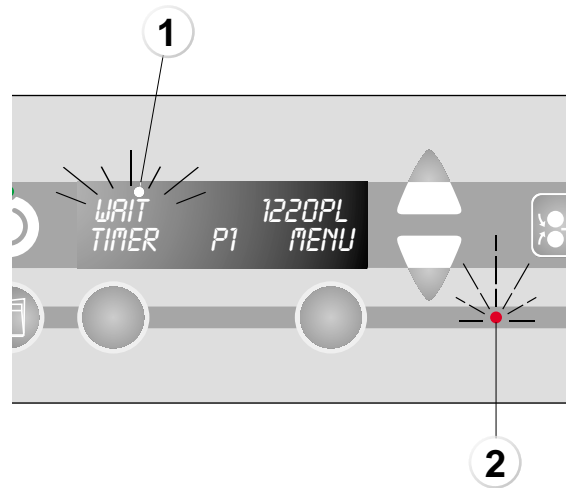

MPA/MPT/EPS CONTROL PANEL

Alarms

STATUS MESSAGES - ALARM LAMP - SOUND			
STATUS	ALARM LAMP	SOUND	EXPLANATION / ACTION
ALARM	Flashing	Yes	<p>The processor is displaying one or more alarms or messages in the alarm list.</p> <p>Some alarms/messages require a minor repair or replacement/emptying/refilling of container(s), but the processor can still be operated.</p> <p>Other alarms/messages will make the processor stop immediately and it cannot be started until the condition causing the alarm has been repaired.</p> <p>"DISPLAYING ALARMS" is described on page 2.16.</p>
BUSY	Lit	No	<p>A plate is entered into the processor. The processor input sensor is activated.</p> <p>Do not enter another plate until display shows PROC or READY.</p>
PROC	Off	No	<p>The processor is processing. Another plate can be entered for processing.</p>
READY	Off	No	<p>The processor is ready to receive a plate.</p>
WAIT	Lit	No	<p>The processor is busy reestablishing suitable conditions for processing. Wait until display changes to READY.</p> <p>Press the help text key to display the actual wait message.</p>
MAN.START	Off	No	<p>The manual start key has been activated.</p> <p>"MANUAL START KEY" is described on page 1.7.</p>

MPA/MPT/EPS CONTROL PANEL

Alarms

ALARMS/MESSAGES LIST

HOW TO READ THE ALARMS/MESSAGES LIST

On the following pages is a complete list of alarms and messages that might be displayed on the control panel:

- The ALARM column shows the alarm text as the operator will see it on the control panel display. Alarm text written in parenthesis shows the alarm text displayed when entering the alarm menu as described earlier, *if* the text in the alarm list deviates from an alarm text displayed on top of other displays/messages.
- The number in front of the alarm text refers to the number displayed in the alarm text when pressing the help text key to display the full text version of the alarm.
- The SECTION column shows which section of the processor the alarm is referring to. Abbreviations are explained opposite.

ABBREVIATIONS USED IN THE ALARMS/MESSAGES LIST

CNV	=	Conveyor
DEV	=	Developer section
D.FIL	=	Developer fill*
D.RPL	=	Developer replenish*
DRY	=	Dryer section
D.WAT	=	Developer water*
FIN	=	Finisher section*
F.RPL	=	Finisher replenish*
G.RPL	=	Gum replenish*
GUM	=	Gum section*
HEAT	=	Pre-heat section*
IN	=	Input sensor
MMI	=	Control Panel/ Man Machine Interface
OUT	=	Output sensor
PWASH	=	Pre-wash*
PROC	=	Processor
RIN	=	Rinse section*
TRANS	=	Transport system
WASH	=	Wash section
WASTE	=	Waste container*

*) Some models only

See also explanation of "OPERATING MODES" on page 1.11.

MPA/MPT/EPS CONTROL PANEL

Alarms

ALARMS AND MESSAGES			
ALARM/MESSAGE	SECTION	CAUSE	EXPLANATION / ACTION / REMEDY
TURNING - WAIT		Rollers are turning half a revolution (for cleaning purposes).	Wait until display turns off.
1: COVER OPN (COVER OPN TRANS)	TRANS	The cover is open.	Close cover properly.
2: LOW LEVEL	PWASH DEV WASH RIN FIN GUM	The level is too low.	<p>MPA control: The replenishment system will automatically reestablish correct level(s).</p> <p>MPT control: The replenishment system will automatically reestablish correct level(s). If the auto top-up function (D TOP-UP) is set to "OFF": Press the manual replenish key to add a fixed amount of developer replenishment.</p>
		Sensor error	<p>Make sure that plug to sensor is connected. Power off the processor and reconnect sensor.</p> <p>WARNING! Power off is mandatory for security reasons.</p> <p>If connected call service technician.</p>
3: EMPTY XXX CONT (OVERFLOW)	WASTE	The waste container is full.	<p>Empty waste container. Press "OK". When the alarm occurs the replenish pumps will not operate. This is to prevent that the waste container overflows. The need for replenishment will be added to the account and released (if any) when the waste container has been emptied and the "OK" key pressed.</p>
3: EMPTY XXX WASTE (OVERFLOW)	DEV WASH GUM		
4: XXX TOP-UP STOP (TOP LIMIT)	PWASH DEV WASH FIN	The replenishment system has tried to reestablish the Level in the tank, but has not reached level in time during top-up. See "2: LOW LEVEL".	<p>Make sure drain tube is properly closed. Check hoses for proper connections, bends, and leaks. Refill replenish container(s) if empty. Press "RETRY".</p> <p>Make sure that replenish pumps run. Press manual replenish key to check.</p>
5: REFILL XXX REPL (REPL EMPTY)	DEV WASH FIN GUM	Replenish container is empty.	Refill or replace replenish container.

MPA/MPT/EPS CONTROL PANEL

Alarms

ALARMS AND MESSAGES			
ALARM/MESSAGE	SECTION	CAUSE	EXPLANATION / ACTION / REMEDY
6: TEMP LO	HEAT DEV WASH FIN DRY	Temperature too low in section.	Processor will automatically reestablish correct temperature(s).
		Circulation blocked.	Check circulation flow, filter, and valve. If needed change filter. Clean spray bar.
		Heater element defective.	Call Service Technician.
		Temperature sensor error.	
		Fuse(s) blown.	
7: TEMP HI	HEAT DEV WASH FIN DRY	Temperature too high in section.	Wait until correct temperature(s) is reestablished.
		Circulation blocked.	Check circulation flow, filter, and valve. If needed change filter. Clean spray bar.
		Chiller unit malfunctions.	Call Service Technician.
		Temperature sensor error.	
8: SPEED LOW	TRANS DEV	Supply voltage too low.	Call a service technician.
		Motors worn out or blocked.	
9: SPEED HIGH	TRANS DEV	The speed is too high.	Call service technician.
11: WAIT	CNV PROC	The processor is not ready to receive plates.	Wait until processor is ready. See also alarm no 125.
14: TEMP INCOR	HEAT	The temperature is not stabilized (warming up and/or cooling).	The processor will automatically establish correct temperature. Wait until message disappears. NOTE! When set temperature is reached another 8 min. awaiting uniform heat distributing might last until the alarm disappears .
	DEV WASH FIN		The processor will automatically establish correct temperature. Wait until message disappears.

MPA/MPT/EPS CONTROL PANEL

Alarms

ALARMS AND MESSAGES			
ALARM/MESSAGE	SECTION	CAUSE	EXPLANATION / ACTION / REMEDY
16: SENSOR ERR XXX (SENSOR ERR)	CNV	Cable transmitting busy signal from the conveyor is disconnected.	Reconnect cable.
	PWASH DEV D.FIL D.RPL D.WAT WASH FIN F.RPL RIN GUM G.RPL WASTE	Sensor in tank or container not connected. Sensor in tank or container defective.	Connect sensor. Switch the processor to off mode and then to stand-by mode. If connected call service technician. Call service technician.
17: TEMP REG XXX	HEAT DEV WASH FIN DRY	Processor fails to reach set temperature: Temperature is outside the allowed range for the electronics. Sensor defective. Cold chemistry added.	Sensor defective: Call service technician. Cold chemistry: Switch to off mode and on again.
18: NO TACHO XXX	DEV TRANS	Motor error on transport or brush. Tacho signal is missing.	Press "RESET" to continue. If the error message returns continuously, call service technician.
19: HW VERS	PROC	PCB version not valid.	Press the help text key for exact information. The help text will display which PCB is not valid. Change PCB to version HPU MK4 or MPU MK2.
20: PLATE JAM (PLATE JAM XXX)	CNV	A plate has jammed in the conveyor.	Remove the plate and press "OK" to reset the alarm.
	OUT	Plate's leading edge has not reached the output slot, indicating a plate jam. <u>Probable causes:</u> Plate stuck underneath input sensor. Entrance transport rollers snap locks not locked properly resulting in poor plate transport. "Input/Output sensor displacement" not properly adjusted. Output sensor malfunctioning or defective.	Press "IGNORE", then start the "eject plate" function (see "FUNCTIONS" in chapter 1) or manually remove the plate from the processor. Check snap locks and lock properly. Do not feed too soon, or adjust conveyor whatever matches the processor system (offline or online?). Check sensor. Call a service technician for sensor repair if necessary.

MPA/MPT/EPS CONTROL PANEL

Alarms

ALARMS AND MESSAGES			
ALARM/MESSAGE	SECTION	CAUSE	EXPLANATION / ACTION / REMEDY
21: TRAIL EDG XXX	OUT	<p>Plate's trailing edge has not reached the output slot, indicating a plate jam.</p> <p><u>Probable causes:</u></p> <p>One or more of the transport roller snap locks near the output sensor not locked properly resulting in poor plate transport.</p> <p>Plate gap too short to detect.</p> <p>Output sensor malfunctioning or defective.</p>	<p>If possible press "REVERSE" otherwise press "IGNORE", then start the "eject plate" function (see "FUNCTIONS" in chapter 1) or manually remove the plate from the processor.</p> <p>Check snap locks and lock properly.</p> <p>Increase plate gap by either increasing processor speed or decreasing setter/conveyor speed.</p> <p>Check sensor. Call a service technician for sensor repair if necessary.</p>
22: LEN. MAX XXX	IN	<p>Plate's trailing edge has not left the input slot, indicating a plate jam.</p> <p><u>Probable causes:</u></p> <p>Plate gap too short to detect.</p> <p>Input sensor defective or malfunctioning.</p> <p>New plate to be entered is resting on the input sensor.</p>	<p>Press OK.</p> <p>Do not feed too soon, or adjust conveyor, whatever matches the processor system (offline or online?)</p> <p>Check sensor. Call a service technician for sensor repair if necessary.</p>
25: MOTOR STOP XXX (MOTOR ERR)	DEV WASH TRANS	<p>Motor overloaded due to mechanical damage or foreign object in the drive system, jam, or poor cleaning.</p> <p>Safety fuse activated.</p>	<p>If the cause demands for repair call service technician. Otherwise solve the problem and press "RESET" to reset safety fuse and remove the alarm.</p> <p>This alarm will most likely leave the plate in the processor. Use the "eject plate" function (see "FUNCTIONS" in chapter 1) to clear the processor.</p> <p>In case a plate is jammed, remove it manually.</p> <p>If the alarm returns continuously, call service technician.</p>
30: RTC MEM RESET (RTC MEM)	MMI	<p>Real Time Clock (RTC) memory error, or low battery due to long period with main power off.</p>	<p>Press OK.</p> <p>NOTE! All statistics values and clock have been reset due to low battery.</p> <p>Battery on MPU board will recharge automatically when power is turned on.</p> <p>If the alarm returns continuously call service technician.</p>

MPA/MPT/EPS CONTROL PANEL

Alarms

ALARMS AND MESSAGES			
ALARM/MESSAGE	SECTION	CAUSE	EXPLANATION / ACTION / REMEDY
34: REFILL XXX FILL (FIL EMPTY)	DEV	Low level in developer fill container	Refill or replace container.
35: REFILL XXX WATER (WATER EMPT)	DEV	Low level in the water container.	Check water supply connection to the water container. Check float valve.
36: REPL WAIT	DEV	Replenishment system busy.	Wait until processor is ready. The alarm is displayed when pumping of large amounts of replenishment is not yet completed.
43: FILLING XXX	PWASH DEV WASH FIN	Fill is needed. The message is displayed until fill-up stops.	The tank will be filled automatically. The message will automatically disappear when tank is full. Wait until message disappears.
44: LEVEL ERROR XXX (LEVEL ERR XXX)	PWASH DEV WASH FIN	The alarm is issued if the level is still low after automatic filling.	Check for leaks. The level error alarm can be cleared by opening and closing the top cover, or by turning the processor off and on again and thereby activating the automatic top-up.
45: STARTING XXX	PWASH DEV WASH FIN	When the processor is turned on, or the cover is closed (processor is not processing) the pump starts 3 times (20 sec. each time) to remove air traps in the hoses. Subsequently the wash tank is checked for correct level.	If top-up is needed the warning will change to "FILLING XXX" and the tank will be filled automatically.
59: MOTOR FAIL XXX (MTR. FAIL)	WASH	Cable for centrifuge motor is not connected, or software is not configured correctly.	Press "EXIT". Turn the main power off and connect cable for the centrifuge motor. If cable is connected, call service technician.
85: CHANGE	DEV	Max. plate area counter for "D CHEM" exeeded. The processor will not accept new plates.	Change developer solution. Press "RESET". CAUTION! Pressing "RESET" will reset plate area counter for "D CHEM". Replace periods (max. plate area before developer alarms occur) can be adjusted by a service technician.

MPA/MPT/EPS CONTROL PANEL

Alarms

ALARMS AND MESSAGES			
ALARM/MESSAGE	SECTION	CAUSE	EXPLANATION / ACTION / REMEDY
90: CHANGE FILTER (CHANGE FLT XXX)	PWASH DEV WASH	Developer filter area exceeded. The processor will not accept new plates.	Change filter. Press "RESET". CAUTION! Pressing "RESET" will reset filter area counter. Replace periods (max. plate area before filter alarms occurs) can be adjusted by a service technician.
91: FILTER 1/4 92: FILTER 2/4 93: FILTER 3/4 94: FILTER 4/4	PWASH DEV WASH	The filter must be changed as soon as possible. The number 1/4-4/4 indicates the number of alarm appearances out of 4. When alarm 1/4 appears max. 20 m ² of plate can be processed before system stops.	Press "OK" to remove the sound from the alarm. If the filter is changed during this period of alarms the statistics value must be reset manually. Enter the STATISTICS menu and go to the D FILT parameter. Press "RESET" to reset the counter.
95: CHANGE FLT	PWASH DEV WASH	Developer filter area counter limit reached.	This alarm changes to alarm No 90, when processing stops. See "90: CHANGE FILTER".
103: CHANGE BRUSH (CHANGE BRSH XXX)	DEV WASH	Brush worn out.	Change brush. Press "RESET". CAUTION! Pressing "RESET" will reset brush counter. Replace periods (max. process length before brush alarm occurs) can be adjusted by a service technician).
104: BRUSH 1/4 105: BRUSH 2/4 106: BRUSH 3/4 107: BRUSH 4/4	TRANS DEV	The brush must be changed as soon as possible. The number 1/4-4/4 indicates the number of alarm appearances out of 4. When alarm 1/4 appears max. 200 m of plate can be processed before system stops.	Press "OK" to remove the sound from the alarm. If the brush is changed during this period of alarms the statistics value must be reset manually. Enter the STATISTICS menu and go to the BRUSH parameter. Press "RESET" to reset the counter.
108: CHANGE BRSH	TRANS DEV	Brush counter limit reached.	This alarm changes to alarm No 103, when processing stops. See 103: CHANGE BRUSH.

MPA/MPT/EPS CONTROL PANEL

Alarms

ALARMS AND MESSAGES			
ALARM/MESSAGE	SECTION	CAUSE	EXPLANATION / ACTION / REMEDY
110: PRIMING	DEV	Possible air pockets in hoses.	<p>Main power has been turned off or replenishment container has been replaced. The priming ensures that air pockets in the circulation system are removed. The processor automatically starts priming when switched into stand-by mode.</p> <p>Priming: 250 ml of replenishment is pumped into the circulation system. Then the circulation pump will stop and start for 10 sec. and 20 sec. respectively, three times in total.</p> <p>After priming the processor is ready to process.</p>
111: PLATE TAIL OUT (TAIL OUT)	OUT	<p>Plate has exited output sensor ahead of schedule.</p> <p><u>Probable causes:</u> Plate has been dragged out of the processor ahead of time e.g. by a conveyor.</p> <p>"Input/Output sensor displacement" not adjusted properly.</p> <p>Processor runs too fast caused by a defective motor.</p>	<p>Press "OK".</p> <p>Adjust conveyor transport speed.</p> <p>If the alarm returns continuously, call service technician.</p>
112: PLATE HEAD OUT (HEAD OUT)	OUT	<p>Plate has activated output sensor ahead of schedule.</p> <p><u>Probable causes:</u> "Input/Output sensor displacement" not properly adjusted.</p> <p>Processor runs too fast caused by a motor error.</p>	<p>Check motor and transport system.</p> <p>Call a Service Technician.</p>
113: STARTING GUM	GUM	The stand-by key has been activated while processor was in off mode. The gum rinse program has automatically been activated.	<p>Wait until the gum process has finished. EXIT will remove the alarm text from the display top level. STOP will stop the gum rinse process (on processors with gum water replenish the process will continue for another 5 min. approx.).</p> <p>The processor automatically switches to stand-by mode after end process (approx. 20 minutes).</p>

MPA/MPT/EPS CONTROL PANEL

Alarms

ALARMS AND MESSAGES			
ALARM/MESSAGE	SECTION	CAUSE	EXPLANATION / ACTION / REMEDY
114: HIGH OFF D.REPL (HIGHOFF)	DEV	The processor has been in off mode (or power off) for a long period. The replenishment system will add an amount of replenish larger than half the amount of the tank volume unless the operator chooses to change the entire developer solution instead.	Press "STOP" to cancel addition of developer replenishment or press "START" to add accumulated replenishment. NOTE! Once START is pressed the system will add an amount of replenish larger than half the amount of the tank volume. This can be interrupted <u>only</u> by turning the main power off. Please note that interrupting will cause the time replenishment amount to be lost.
114: WSH REPL 5000 ml?	WASH	The processor has been in off mode (or power off) for a long period. The replenishment system will add 5000 ml of replenish to the wash section unless the operator chooses to change the entire wash solution instead.	Press "STOP" to cancel addition of wash replenishment or press "START" to add replenishment. NOTE! Once START is pressed the system will add 5000 ml of replenish. This can be interrupted <u>only</u> by turning the main power off. Please note that interrupting will cause the time replenishment amount to be lost.
115: STOPPING GUM	GUM	The processor has been switched to off mode while processor was in stand-by mode. A process drying the gum rollers has started automatically.	Drying the gum rollers will last for approx. 10 minutes. The processor will automatically switch to off mode after end process. Pressing STOP will stop the process immediately. CAUTION! If the process is stopped and the processor is left in off mode for a long period e.g. over night, residual gum might cause the rollers to stick together and demand for cleaning.

MPA/MPT/EPS CONTROL PANEL

Alarms

ALARMS AND MESSAGES			
ALARM/MESSAGE	SECTION	CAUSE	EXPLANATION / ACTION / REMEDY
117: BAR POSITION OK?	DEV	The manual replenish key has been activated and replenishment has been pumped for replenishment purpose or for extrusion of air bubbles trapped in the replenishment system.	Open the top cover. Lower the coating bar to its original position. Close the top cover and press "OK". See also description of manual replenish key on page 1.7. CAUTION! Only press "OK" when coating bar is back in place.
118: D.CHEM 1/4 119: D.CHEM 2/4 120: D.CHEM 3/4 121: D.CHEM 4/4	DEV	The developer solution must be changed as soon as possible. The number 1/4-4/4 indicates the number of alarm appearances out of 4. When alarm 1/4 appears max. 100 m ² of plate can be processed before system stops.	Press "OK" to remove the sound from the alarm. If the developer solution is changed during this period of alarms the statistics value must be reset manually. Enter the STATISTICS menu and go to the D CHEM parameter. Press "RESET" to reset the counter.
122: CHANGE DEV	DEV	Max. plate area counter limit reached.	This alarm changes to alarm No 85, when processing stops. See "85: CHANGE DEV".
123: CHANGE CHEMISTRY (CHANGE CHEM XXX)	DEV WASH	The processor has been in off mode (or power off) for a long period: MPA/MPT Control: The replenishment system has calculated an amount of replenish larger than the actual tank volume. No replenishment will be pumped. EPS Control: The replenishment system has calculated more than 5000 ml of replenish. No replenishment will be pumped.	Switch the processor off and change chemistry. Switch the processor on again. Note! This message might occur if chemistry has just been changed. In that case press "OK".
125: WAIT	PROC	Processor not ready e.g. top cover has been opened.	The processor will automatically switch to stand-by mode (READY) when software is ready. See also alarm no 11.

MPA/MPT/EPS CONTROL PANEL

Alarms

REPLY MENUS		
DISPLAY TEXT	DESCRIPTION	ACTION
ARE YOU SURE ?	<p>This question is displayed when entering some menus:</p> <ol style="list-style-type: none">1. The question is displayed for confirmation entering the menu in question.2. Menus allowed for Service technicians only. A special entry code is required.	<ol style="list-style-type: none">1. YES confirms settings and NO gives the opportunity to change the input.2. Service technicians only.

MPA/MPT/EPS CONTROL PANEL

Alarms

MPA/MPT/EPS CONTROL PANEL

Alarms

EXPLANATION OF THE ALARM DISPLAY

DISPLAYING ALARMS

Alarms are shown in the display (1) like the example:

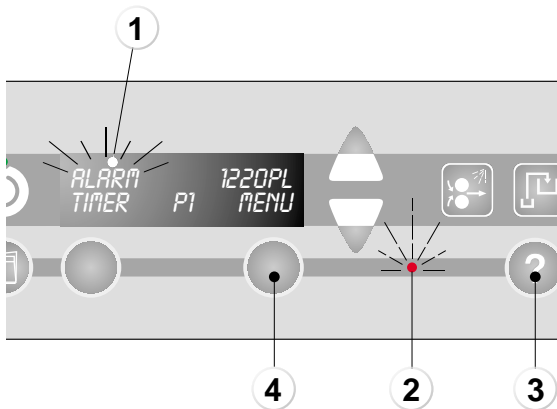

- Messages will always be displayed in the upper line of the display. When a message (1) is displayed the alarm lamp (2) may also be flashing/lit.
- Press the help text key (3) to display the alarms/messages (see also "HELP-TEXT KEY" on page 1.9), or
- Enter the alarm list (if the displays shows "ALARM") by pressing "MENU" (4) and select the ALARMS function.
- Use the up/down arrows to scroll through the alarms/messages. Alarms/messages displayed are explained in the list of alarms and messages earlier in this chapter.

NOTE! Entering the "ALARMS" function will freeze the current alarms.

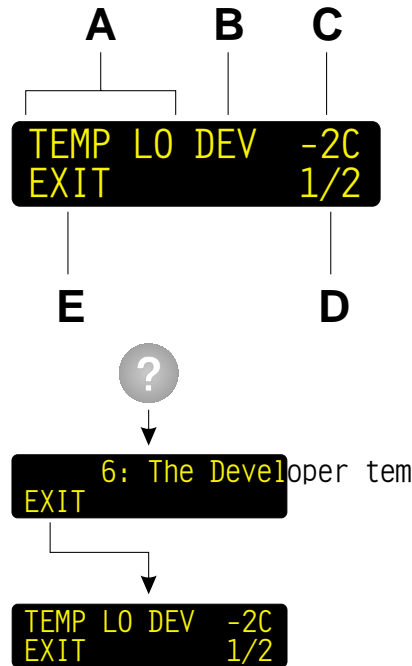

- A:** The alarm is specified by a short description. Press the help-text key to display a full text version. The full text version also shows a number. Use this number to find the alarm in the alarm list in this chapter.
- B:** Section to which the alarm refers. See the list of abbreviations earlier in this chapter.
- C:** Values deviating from the programmed value.
- D:** The number "1/2" indicates that the alarm currently displayed is the first of 2 alarms detected. Press the up/down keys to scroll between the alarms. If there is a change in the alarms during displaying e.g. if an alarm disappears or if a new alarm occurs, the lower right corner of the display will change to show "REFRESH". Press "REFRESH" to redisplay current alarms.
- E:** Press exit to return to stand-by display.

USER ACTION

Alarms requiring immediate user action will always appear **on top of other displays/messages**, e.g.:



EMPTY WASTE CONT
EXIT OK

EXIT

“EXIT” will skip the alarm for 1 min. and the display will either return to the stand-by/processing display (showing "ALARM") or it will show the next alarm with user action (if any).

OK

“OK” and "RESET" will reset the alarm if the required action has been executed. The display will either return to stand-by/processing display or it will show the next alarm with user action (if any).

CAUTION! It is very important for the correct function of the processor that the required action is executed before resetting the alarm, as some alarms will automatically reset counters etc.

MPA/MPT/EPS CONTROL PANEL

Alarms

3. CUSTOMERS NOTES

PARAMETER SETTINGS LISTS

Make notes of your current processor settings in the table in this chapter. The notes will make the service technician able to make same settings later if changing the software.

NOTE! Parameters in bold italic in the tables on the next pages are not available for all processor variants or depending on configuration.

MPT CONTROL PANEL

MENU	PARAMETER	VALUE
PROGRAMS PROGRAM 1	SPEED	
	DIP/NIP	
	DEV TEMP	
	HEAT TEMP	
	PW RPL	
	D RPL	
	D TOPUP	
	DEV BRUSH	
	W RPL	
	DRY TEMP	
PROGRAMS PROGRAM 2	SPEED	
	DIP/NIP	
	DEV TEMP	
	HEAT TEMP	
	PW RPL	
	D RPL	
	D TOPUP	
	DEV BRUSH	
	W RPL	
	DRY TEMP	
PROGRAMS PROGRAM 3	SPEED	
	DIP/NIP	
	DEV TEMP	
	HEAT TEMP	
	PW RPL	
	D RPL	
	D TOPUP	
	DEV BRUSH	
	W RPL	
	DRY TEMP	
PROGRAMS PROGRAM 4	SPEED	
	DIP/NIP	
	DEV TEMP	
	HEAT TEMP	
	PW RPL	
	D RPL	
	D TOPUP	
	DEV BRUSH	
	W RPL	
	DRY T2EMP	

MPT CONTROL PANEL

MENU	PARAMETER	VALUE
SETUP CONTROL PANEL	LEFT KEY	
	DISP	
	DISPLAY LIGHT	
	DISPLAY CONTRAST	
	SOUND	
	BLACK OUT	
	EDIT LOCK	
SETUP PLATE SIZES	S1	
	S2	
	S3	
	S4	
	S5	
	S6	
	S7	
	S8	
SETUP INFORMATION MPT x.xx.xx x	(Software version)	
SETUP INFORMATION ABSOLUTE VALUES	PLATES	
	AREA	
	HOURS	
	D CHEM	
	<i>PW FILT</i>	
	D FILT	
	BRUSH	
<i>W FILT</i>		
SETUP AUTO TIMER		
SETUP CLOCK	(Set actual date and time)	
<i>NOTE! Parameters in bold italic are not available for all processor variants or depending on configuration.</i>		

MPT CONTROL PANEL
